

ALIGN PILOT AND HOLE IN GASKET, SIDE 'A' ONLY FOR EXTERNAL PILOT OPERATION - ROTATE THE ROUND ALUMINUM ADAPTOR 180 DEGREES. REMOVE 1/8" NPTF PLUG AND SUPPLY 50-150 PSI TO 1/8" NPTF PILOT PORT IN ADAPTOR.

- NOTES:
 1) ALWAYS GIVE VALVE MODEL AND PART NUMBER WHEN ORDERING PARTS.
 2) FOR DIFFERENT VOLTAGES OTHER THAN 120/60, REPLACE SOLENOID COIL WITH COIL LISTED IN TABLE BELOW.

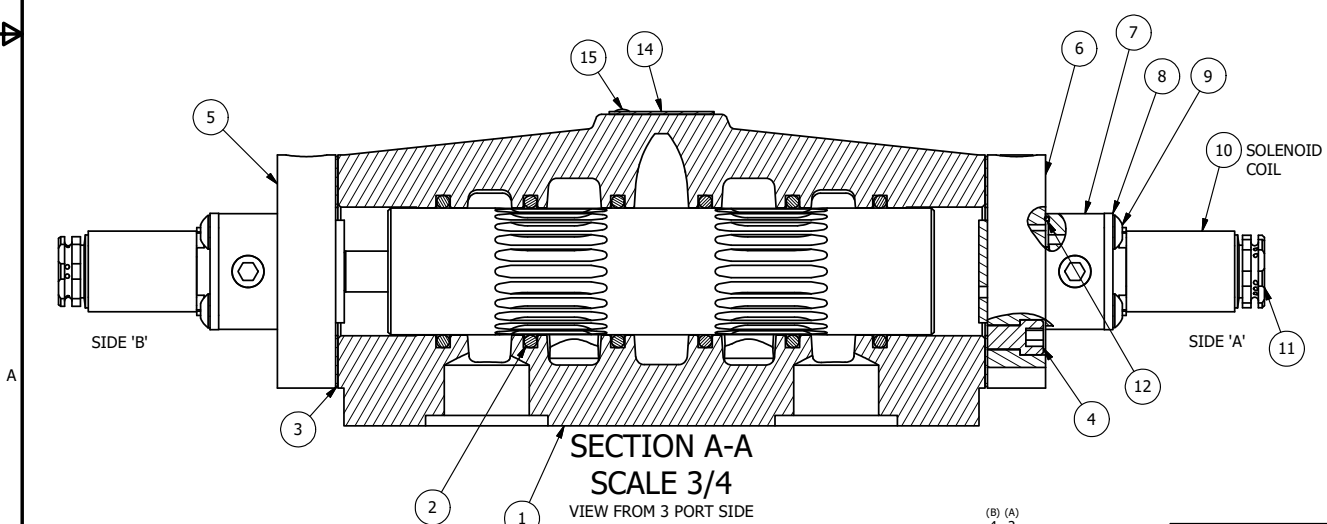

| | | | |
|-----|-----|----------|---|
| 15 | 2 | V-212 | SCREW, #2 X 3/16 DRIVE, TYPE U, OVAL HEAD, STAINLESS STEEL |
| 14 | 1 | AN-114 | NAMEPLATE, BLANK, FOR VALVES WITH SPRINGS OR DETENTS |
| 13 | 2 | V-19 | PLUG, SOCKET PIPE 1/8" NPT (#601-3 PITTSBURG PLUG PART #.) |
| 12 | 2 | EMG3 | GASKET - END MOUNT SOLENOID, BUNA-N, 1/4" & 3/8" VALVES |
| 11 | 2 | V-562 | NUT, SOLENOID, SIDE EXHAUST |
| 10 | 2 | V-569-1 | SYSTEM 8 COIL 120 50/60.NASS # 0561 38.1 00/4984. |
| 9 | 8 | V-584 | SCREW, 10-24 X 1, BUTTON HEAD SOCKET CAP WITH MICROSPHERE APPLIED TO THREADS. |
| 8 | 2 | SEC3-7 | PLATE, RE-INFORCEMENT, SOLENOID, STAMPED, 304 STAINLESS |
| 7 | 2 | V-599-1 | SOL OPER, END MOUNT, LOCKING O'RIDE |
| 6 | 1 | SSA48-1E | ADAPTOR, END MNT SOLENOID, 1/2", 3/4" & 1" VALVE |
| 5 | 1 | AY-ESY8G | ASSY - SPR CTR, FLOAT CTR SPOOL, END MOUNT SOLENOID, 3/4" & 1" VALVES |
| 4 | 8 | V-46 | SCREW, 1/4-20 X 3/4, SOCKET HEAD CAP |
| 3 | 2 | ECG48 | GASKET - END CAP, 1/2", 3/4" & 1" VALVE |
| 2 | 6 | V-30 | O-RING, BUNA-N, 70 DURO, AS-220, (REF 1-3/8 X 1-5/8 X 1/8), 3/4" & 1" VALVES |
| 1 | 1 | BP8-1 | BODY, 1" SUBPLATE, UPPER PILOTS, ANODIZED |
| FLG | QTY | PART NO | DESCRIPTION |

LIMITS ON DIMENSIONS UNLESS OTHERWISE SPECIFIED
 2-PL DECIMAL ± .01
 3-PL DECIMAL ± .005
 FRACTIONAL ± 1/64
 ANGULAR ± 1/2°

AAA PRODUCTS INTERNATIONAL
 7114 Harry Hines Blvd
 Dallas, TX 75235

DRAWN: RMckenna DATE: 4/8/2016 CHECKED: KWaite DATE: 4/8/2016
 SCALE: 1 : 1 SHEET: 1 OF 1 RELEASED: HWomack DATE: 4/8/2016

| COIL VOLTAGES | |
|------------------|--------------|
| PART NO | REPLACE COIL |
| ESY8PGMOC 12VDC | V-569-2 |
| ESY8PGMOC 24VDC | V-569-3 |
| ESY8PGMOC 240/60 | V-569-4 |

TITLE:
**1" SUBPLATE, DBL SOL, 3 POS,
 FLOAT SPR CTR, FLYING LEAD,
 120/60, LCKNG OVRD, SIDE VENT**

PART NO.:
ESY8PGMOC

THE INFORMATION CONTAINED WITHIN THIS DOCUMENT IS PROPRIETARY TO AAA PRODUCTS AND MAY NOT BE DISCLOSED WITHOUT PRIOR WRITTEN CONSENT

D:\Engineering\Product Valve Assembly\Standard\ESY8PGMOC.dwg