

4 | 3 | 2 | 1

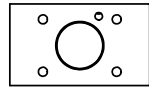
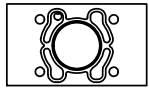
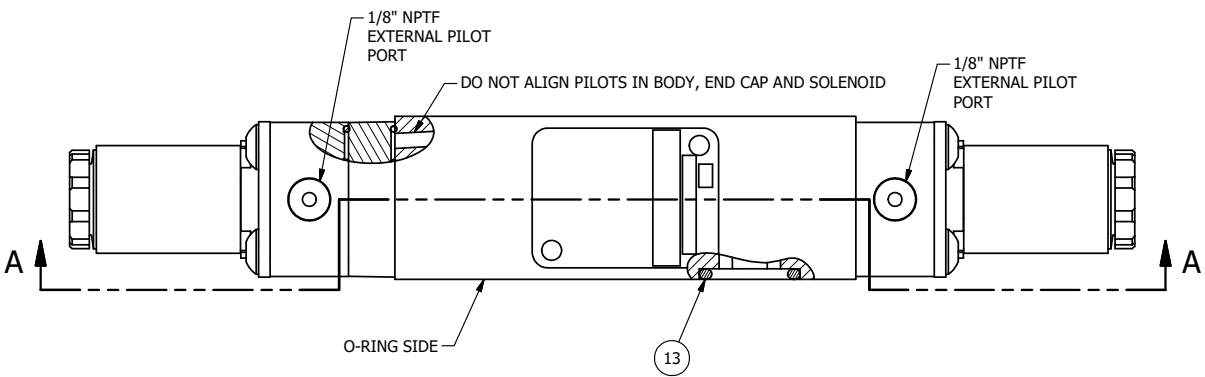

POSITION GASKET AND AY-EMY3D ON END OF VALVE, DO NOT ALIGN PILOT HOLES (SIDE 'B' ONLY)

ALIGN PILOT AND SLOT IN ADAPTOR WITH GASKET IN BETWEEN, BOTH SIDES (ADAPTOR SHOULD BE INSTALLED AS SHOWN) SUPPLY 50-150 PSI TO 1/8\"/>

NOTES:  
1) ALWAYS GIVE VALVE MODEL AND PART NUMBER WHEN ORDERING PARTS.

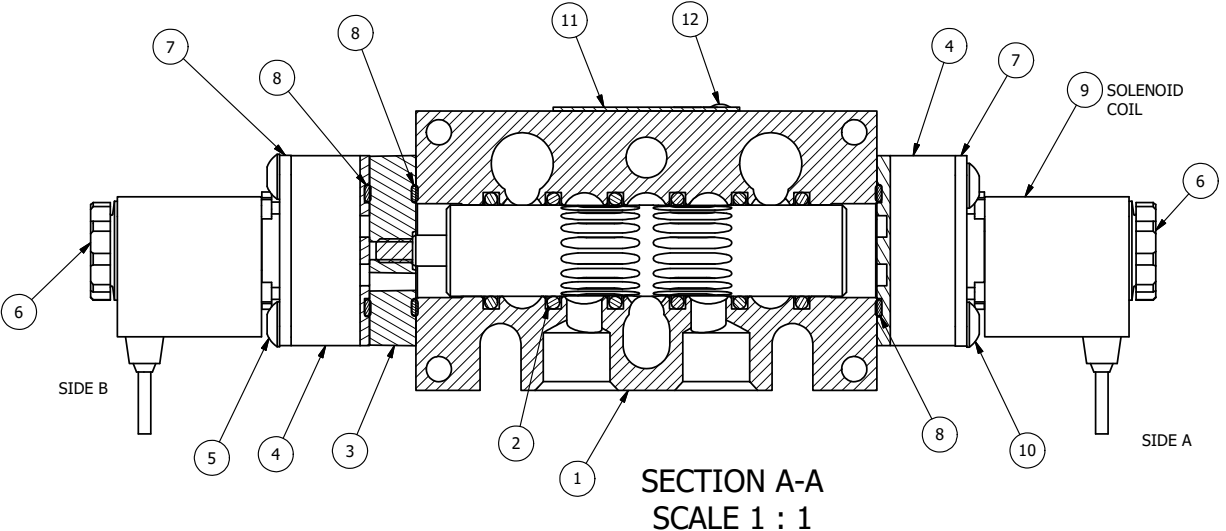

13	3	V-110	O-RING, BUNA-N, 70 DURO, AS-114, (REF 5/8 X 13/16 X 3/32), 1/4" SLEEVE, 1/2" SUB, STACK
12	2	V-212	SCREW, #2 X 3/16 DRIVE, TYPE U, OVAL HEAD, STAINLESS STEEL
11	1	AN-114	NAMEPLATE, BLANK, FOR VALVES WITH SPRINGS OR DETENTS
10	4	V-584	SCREW, 10-24 X 1, BUTTON HEAD SOCKET CAP WITH MICROSPHERE APPLIED TO THREADS.
9	2	V-569-1	SYSTEM 8 COIL 120 50/60.NASS # 0561 38.1 00/4984.
8	3	EMG3	GASKET - END MOUNT SOLENOID, BUNA-N, 1/4" & 3/8" VALVES
7	2	SEC3-7	PLATE, RE-INFORCEMENT, SOLENOID, STAMPED, 304 STAINLESS
6	2	V-556	NUT, SOLENOID, TOP EXHAUST, KNURLED
5	4	V-601	SCREW, 10-24 X 1-1/2, BUTTON HEAD SOCKET CAP WITH MICROSPHERE ADHESIVE
4	2	V-550-1	SOL OPER, END MOUNT, NON-LOCKING O'RIDE
3	1	AY-EMY3D	ASSY - SPR CTR, REGEN CTR SPL, END MOUNT SOLENOID, 1/4" & 3/8" VALVES
2	6	V-39	O-RING, VITON, STD BODY, 1/4" & 3/8" VALVES
1	1	B3-10E	FINISHED - SOLID BODY, UPPER PILOTS, 3/8" STACKING VALVE
FLG	QTY	PART NO	DESCRIPTION

LIMITS ON DIMENSIONS UNLESS OTHERWISE SPECIFIED  
2-PL DECIMAL ± .01  
3-PL DECIMAL ± .005  
FRACTIONAL ± 1/64  
ANGULAR ± 1/2°



DRAWN: RMckenna DATE: 6/8/2016 CHECKED: KWaite DATE: 6/8/2016  
SCALE: 1:1 SHEET: 1 OF 1 RELEASED: HWomack DATE: 6/8/2016

COIL VOLTAGES	
PART NO	REPLACE COIL
EBSY3DMZ 12VDC	V-569-2
EBSY3DMZ 24VDC	V-569-3
EBSY3DMZ 240/60	V-569-4

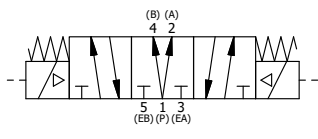

A	NO.	DATE	REVISION
	6/1/2018	ECG3 GASKET TO EMG3, SPL ASSY TO AY-EMY3D.	

TITLE: 3/8" STACK, DBL SOL, 3 POS, SPR CTR, SOL SHFT, REGEN CTR SPL, FLYING LEAD, 120/60, EXT PILOT  
PART NO.: EBSY3DMZ  
REV.: A

THE INFORMATION CONTAINED WITHIN THIS DOCUMENT IS PROPRIETARY TO AAA PRODUCTS AND MAY NOT BE DISCLOSED WITHOUT PRIOR WRITTEN CONSENT

4 | 3 | 2 | 1