

4

3

2

1

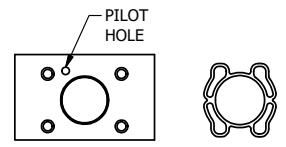

ALIGN PILOT AND SLOT IN ADAPTOR WITH GASKET IN BETWEEN, BOTH SIDES (ADAPTOR SHOULD BE INSTALLED AS SHOWN)
SUPPLY 50-150 PSI TO 1/8" NPTF PILOT PORT IN ADAPTOR.

NOTES:
1) ALWAYS GIVE VALVE MODEL AND PART NUMBER WHEN ORDERING PARTS.

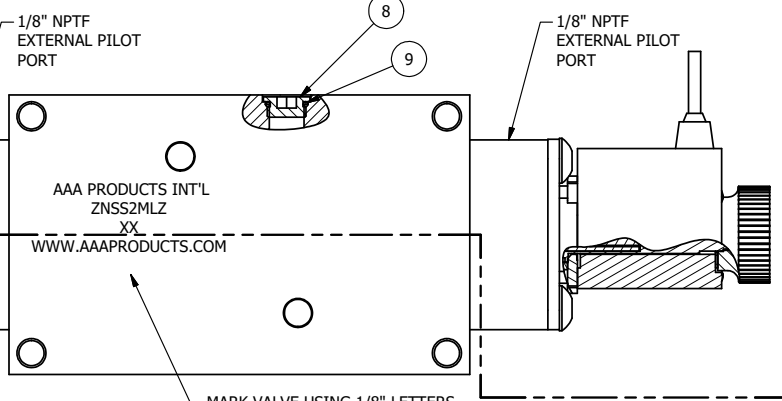

AAA PRODUCTS INT'L
ZNSS2MLZ
XX
WWW.AAAPRODUCTS.COM

MARK VALVE USING 1/8" LETTERS WHERE XX IS THE DATE CODE

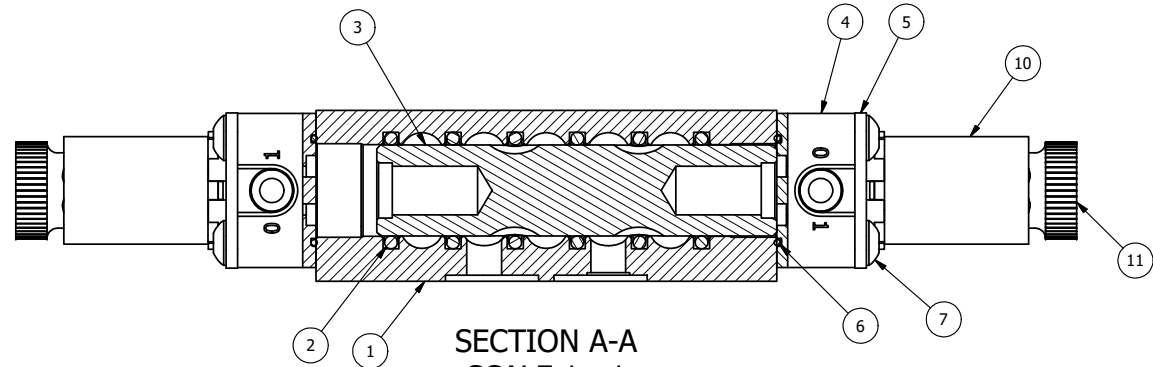

SECTION A-A
SCALE 1 : 1
VIEW FROM 3 PORT SIDE

12	1	ZNSPK-2	KIT - SUBPLATE MOUNTING, BRASS NAMUR, (2 EA V-618-SS SCREW, 2 EA V-565 O-RING)
11	2	V-567W	E SERIES SINTERED BRONZE MUFFLER, DUST EXCLUDER, V-613 LOCK WASHER
10	2	V-569-1	SYSTEM 8 COIL 120 50/60.NASS # 0561 38.1 00/4984.
9	1	V-548	O-RING, BUNA-N, 70 DURO, 6MM X 1MM, NAMUR PLUG
8	1	V-547	PLUG, 360 HALF HARD BRASS, NAMUR VALVE
7	8	V-584-SS	SCREW, 10-24 X 1, BUTTON HEAD SOCKET CAP, 18-8 OR 303 SS
6	2	EMG3	GASKET - END MOUNT SOLENOID, BUNA-N, 1/4" & 3/8" VALVES
5	2	SEC3-7	PLATE, RE-INFORCEMENT, SOLENOID, STAMPED, 304 STAINLESS
4	2	V-550-1	SOL OPER, END MOUNT, NON-LOCKING O'RIDE
3	1	S3R	SPOOL - SOLID, STANDARD, 2 POS, CLSD CTR, 1/4" & 3/8" VALVE
2	6	V-39	O-RING, VITON, STD BODY, 1/4" & 3/8" VALVES
1	1	Z2-11	BODY - BRASS, UPPER PILOTS (BUTTON BLEEDER), 1/4" NAMUR
FLG	QTY	PART NO	DESCRIPTION

LIMITS ON DIMENSIONS UNLESS OTHERWISE SPECIFIED
2-PL DECIMAL ± .01
3-PL DECIMAL ± .005
FRACTIONAL ± 1/64
ANGULAR ± 1/2°

AAA PRODUCTS INTERNATIONAL
7114 Harry Hines Blvd
Dallas, TX 75235

DRAWN: RMckenna DATE: 2/13/2019 CHECKED: KWaite DATE: 2/13/2019
SCALE: 1 : 1 SHEET: 1 OF 1 RELEASED: HWomack DATE: 2/13/2019

COIL VOLTAGES	
PART NO	REPLACE COIL
ZNSS2MLZ 12VDC	V-569-2
ZNSS2MLZ 24VDC	V-569-3
ZNSS2MLZ 240/60	V-569-4

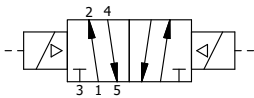

TITLE:
1/4" NAMUR, DBL SOL, 2 POS,
SOL RTRN, BR & SS, FLYING LEAD,
120/60, DUST EXCLDR, EXT PILOT

PART NO.:
ZNSS2MLZ

THE INFORMATION CONTAINED WITHIN THIS DOCUMENT IS PROPRIETARY TO AAA PRODUCTS AND MAY NOT BE DISCLOSED WITHOUT PRIOR WRITTEN CONSENT

4

3

2

1

D:\Engineering\product\Valves\Assembly\Standards\SS\DWG\ZNSS2MLZ.dwg