

1/4" NPTF EXTERNAL PILOT PORT

ALIGN END CAP PILOT WITH BODY PILOT HOLE BOTH ENDS

- NOTES:
 1) ALWAYS GIVE VALVE MODEL AND PART NUMBER WHEN ORDERING.
 2) OPEN MUFLER 2 TURNS FROM CLOSED POSITION. TIGHTEN LOCK NUT ON MUFLER.
 3) INSTALL MUFLER WITH MAGNALUBE-G GREASE 1 TO 1-1/2 TURNS FROM HAND TIGHT INTO BODY.
 4) FOR DIFFERENT VOLTAGES OTHER THAN 120/60, REPLACE TOP CONTROL VALVE WITH VALVE LISTED IN TABLE BELOW.

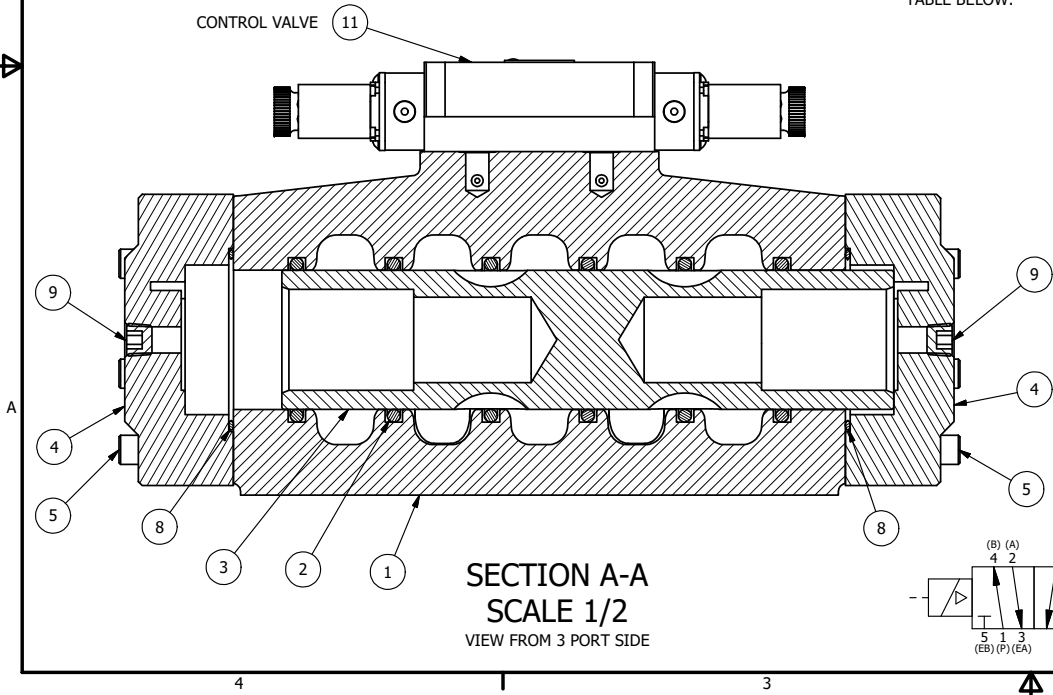

SECTION A-A
 SCALE 1/2
 VIEW FROM 3 PORT SIDE

THE FOLLOWING PARTS ARE INCLUDED WITH THE SUBPLATE VALVE AND ARE USED TO ASSEMBLE.

| QTY | PART NO | DESCRIPTION |
|-----|---------|--|
| 5 | V-92 | O-RING, BUNA-N, 70 DURO, AS-014, (REF 1/2 X 5/8 X 1/16), 3/8" SUBPLATE |
| 4 | V-35 | SCREW, 10-24 X 7/8, SOCKET HEAD CAP |

| | | | |
|-----|-----|---------|---|
| 11 | 1 | ESS3PML | 3/8" SUBPLATE, DBL SOL, 2 POS, FRICTION POS, SOL RTRN, FLYING LEAD, 120/60, DUST EXCLDR |
| 10 | 2 | MFC2 | ASSEMBLY - MUFLER FLOW CONTROL, 1/4" NPT |
| 9 | 2 | V-337 | PLUG, SOCKET 1/4-18 FLUSH SEAL PLUG |
| 8 | 2 | V-124 | O-RING, BUNA-N, 70 DURO, AS-231, (REF 2-5/8 X 2-7/8 X 1/8), 2 POS, 1-1/2" & 2" VALVES |
| 7 | 2 | V-89 | O-RING, BUNA-N, 70 DURO, AS-110, (REF 3/8 X 9/16 X 3/32), 1" & 2" SUBPLATE PILOT |
| 6 | 3 | V-231 | PLUG, SOCKET PRESSURE 1/16-27X 7/8 TAPER FOR 122V,192V,FOR EC |
| 5 | 12 | V-143 | SCREW, 5/16-18 X 2, SOCKET HEAD CAP |
| 4 | 2 | PEC12E | ENDCAP - PILOT, SOLID, 6061-T6 AL, 1-1/2" & 2" VALVES |
| 3 | 1 | S12 | SPOOL - STANDARD, 2 POS - 3 POS CLOSED CTR, 1 1/2" & 2" VALVE |
| 2 | 6 | V-123 | O-RING, BUNA-N, 70 DURO, AS-331, (REF 2-1/4 X 2-5/8 X 3/16), 1-1/2" & 2" VALVES |
| 1 | 1 | B12-6 | BODY, 1 1/2" SIDE PORT, PIGGY BACK |
| FLG | QTY | PART NO | DESCRIPTION |

LIMITS ON DIMENSIONS
 UNLESS OTHERWISE SPECIFIED
 2-PL DECIMAL ± .01
 3-PL DECIMAL ± .005
 FRACTIONAL ± 1/64
 ANGULAR ± 1/2°



DRAWN: RMckenna DATE: 2/13/2019 CHECKED: KWaite DATE: 2/13/2019
 SCALE: 1/2 SHEET: 1 OF 1 RELEASED: HWomack DATE: 2/13/2019

COIL VOLTAGES

| PART NO | REPLACE WITH |
|-----------------|----------------|
| ESS12MLZ 12VDC | ESS3PML 12VDC |
| ESS12MLZ 24VDC | ESS3PML 24VDC |
| ESS12MLZ 240/60 | ESS3PML 240/60 |

TITLE:
 1-1/2" SIDE PORT, DBL SOL, 2 POS,
 SOL RTRN, FLYING LEAD,
 120/60, DUST EXCLDR, EXT PILOT

PART NO.:
 ESS12MLZ

THE INFORMATION CONTAINED WITHIN THIS DOCUMENT IS PROPRIETARY TO AAA PRODUCTS AND MAY NOT BE DISCLOSED WITHOUT PRIOR WRITTEN CONSENT

D:\Engineering\product\Valve Assembly\Standard\DWG\ESS12MLZ.dwg