

POSITION GASKET ON END OF VALVE
TO SEAL PILOT HOLE IF PRESENT,
BOTH SIDES (SIDE 'B' SHOWN)

NOTES:
1) ALWAYS GIVE VALVE MODEL AND PART NUMBER WHEN ORDERING PARTS.

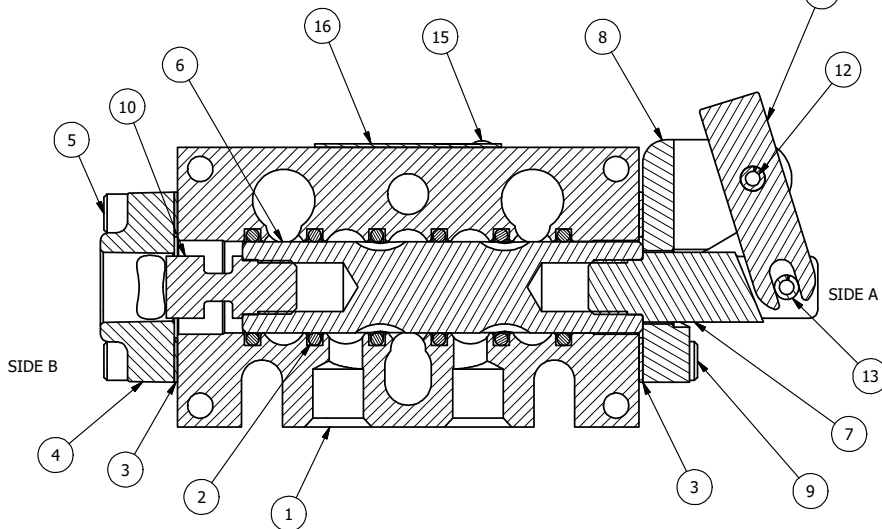
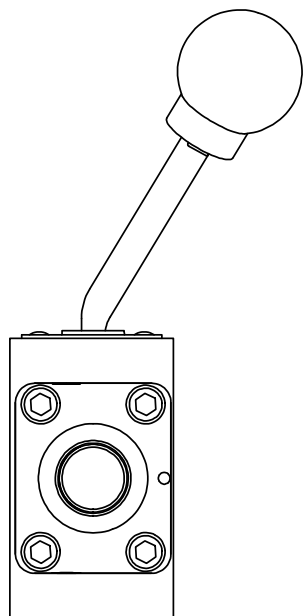

16	1	AN-115	BLANK NAMEPLATE FOR HE,KE,KD,RR,D,CR,PP,SR,SS VALVES.
15	2	V-212	SCREW, #2 X 3/16 DRIVE, TYPE U, OVAL HEAD, STAINLESS STEEL
14	3	V-110	O-RING, BUNA-N, 70 DURO, AS-114, (REF 5/8 X 13/16 X 3/32), 1/4" SLEEVE, 1/2" SUB, STACK
13	1	V-48	PIN, ROLL 3/16 X 9/16, STEEL, ZINC PLATED
12	1	V-542	PIN, ROLL 3/16 X 1/2 ZINC PLATED STEEL FOR HE3-4 END CAP
11	1	HL3-24B30	HAND LEVER WITH KNOB, BENT 30 DEG SIDEWAYS, 1/4" & 3/8" VALVES
10	1	PBS3-402V	STUD - REAR LOCKOUT, POS. A & C, STAINLESS, 1/4" & 3/8" VALVE
9	4	V-162	SCREW, 10-24 X 5/8, SOCKET HEAD CAP
8	1	HE3-4	ENDCAP - HAND OPERATOR, 303 STAINLESS, 1/4" & 3/8" STACK VALVE
7	1	BHC3	CLEVIS - NO DETENTS, 1/4" & 3/8" STACKING VALVE
6	1	S3R	SPOOL - SOLID, STANDARD, 2 POS, CLSD CTR, 1/4" & 3/8" VALVE
5	4	V-38	SCREW, 10-24 X 3/4, SOCKET HEAD CAP
4	1	PEC3-2LO	END CAP, PALM, LOCK OUT, 380 AL, 1/4" & 3/8" VALVE
3	2	ECG3	GASKET - END CAP, 1/4" & 3/8" VALVE
2	6	V-39	O-RING, STD BODY, VITON, 1/4" & 3/8" VALVES
1	1	B2-10E	FINISHED - SOLID BODY, UPPER PILOTS, 1/4" STACKING VALVE
FLG	QTY	PART NO	DESCRIPTION

SECTION A-A
SCALE 1 : 1

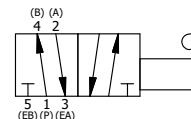

LIMITS ON DIMENSIONS UNLESS OTHERWISE SPECIFIED		2-PL DECIMAL ± .01 3-PL DECIMAL ± .005 FRACTIONAL ± 1/64 ANGULAR ± 1/2°		AAA PRODUCTS INTERNATIONAL 7114 Harry Hines Blvd Dallas, TX 75235
DRAWN: RMckenna	DATE: 5/14/2014	CHECKED: KWhite	DATE: 5/14/2014	
SCALE: 1 : 1	SHEET: 1 OF 1	RELEASED: HWomack	DATE: 5/14/2014	
TITLE: 1/4" STACK, LEVER, 2 POS, FRICTION POS, REAR LCKOUT, BENT LEFT 30DEG		PART NO.:	738V	REV.:

THE INFORMATION CONTAINED WITHIN THIS DOCUMENT IS PROPRIETARY TO AAA PRODUCTS AND MAY NOT BE DISCLOSED WITHOUT PRIOR WRITTEN CONSENT