

ALIGN GASKET SO MOUNTING HOLES ALIGN, BOTH ENDS

NOTES:

- 1) ALWAYS GIVE VALVE MODEL, AND PART NUMBER WHEN ORDERING PARTS.
- 2) LUBRICATE DETENT BALL, SPRINGS AND STUD.

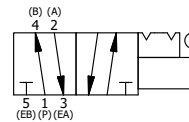
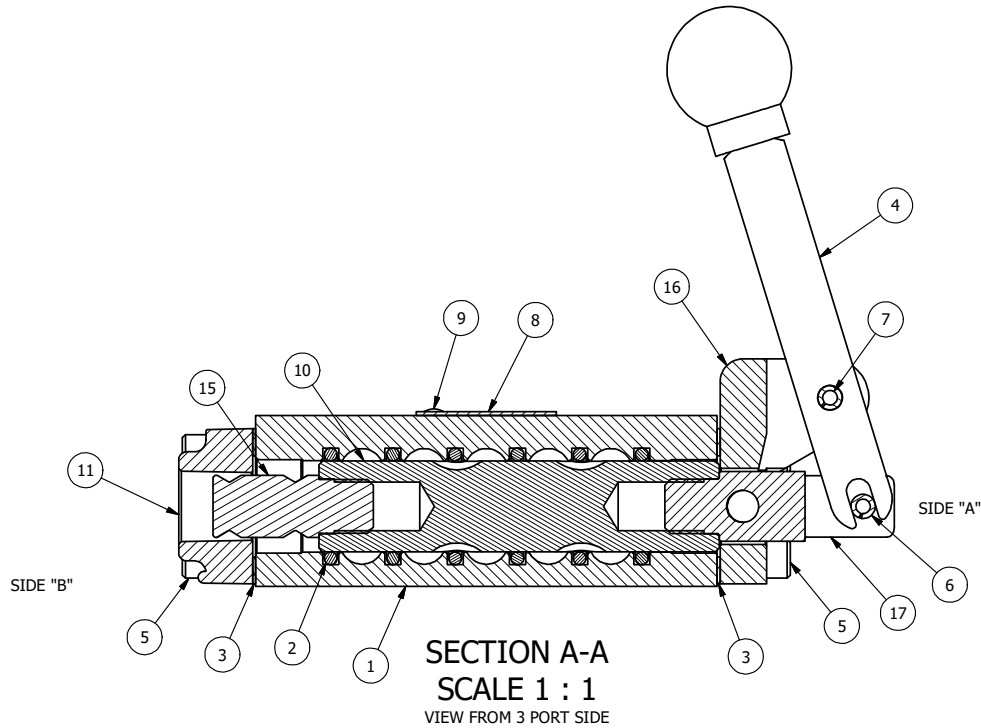

17	1	HC3-ILOC	CLEVIS - POS. C LOCKOUT, 1/4" & 3/8" VALVE
16	1	HE3-ILO	END CAP, LEVER, LOCK OUT, 380 AL, 1/4" & 3/8" VALVE
15	1	PBS3-13	STUD - POS. A & C. DETENT, 1/4" & 3/8" VALVE
14	1	DS3	SPRING - DETENT, 1/4" & 3/8" VALVE
13	1	V-14	BALL, CHROME STEEL 3/16 DIA, GRADE 25, FOR DETENT
12	1	V-21	SCREW, 1/4-20 X 3/16, SOCKET SET, CUP POINT
11	1	PEC3-3	END CAP, PALM, DETENT, 380 AL, 1/4" & 3/8" VALVE
10	1	S3R	SPOOL - SOLID, STANDARD, 2 POS, CLSD CTR, 1/4" & 3/8" VALVE
9	2	V-212	SCREW, 2 X 3/16, DRIVE, TYPE U, OVAL HEAD, 316 SS
8	1	AN-114	NAME PLATE, BLANK, FOR VALVES WITH SPRINGS OR DETENTS.
7	1	V-7	PIN, ROLL 3/16 X 11/16 FOR 1/4 THRU 1/2" HAND, FT. & CAM V
6	1	V-48	PIN, ROLL 3/16 X 9/16 ZINC PLATED STEEL
5	8	V-38	SCREW, 10-24 X 3/4, SOCKET HEAD CAP
4	1	HL3-24	HAND LEVER WITH KNOB, 1/4" & 3/8" VALVE
3	2	ECG3	GASKET - END CAP, 1/4" & 3/8" VALVE
2	6	V-39	O-RING, STD BODY, VITON, 1/4" & 3/8" VALVES
1	1	B2-2E	BODY - SOLID, PLAIN, NO PILOTS, ANODIZED, 1/4" SIDE PORT VALVE
FLG	QTY	PART NO	DESCRIPTION

LIMITS ON DIMENSIONS UNLESS OTHERWISE SPECIFIED		2-PL DECIMAL ± .01 3-PL DECIMAL ± .005 FRACTIONAL ± 1/64 ANGULAR ± 1/2°		AAA PRODUCTS INTERNATIONAL 7114 Harry Hines Blvd Dallas, TX 75235
DRAWN: RMckenna	DATE: 2/14/2012	CHECKED: KWhite	DATE: 5/28/2015	
SCALE: 1 : 1	SHEET: 1 OF 1	RELEASED: HWomack	DATE: 5/28/2015	
TITLE: 1/4" SIDE PORT, LEVER, 2 POS, DETENT, LOCKOUT POS C			PART NO.: 667V	REV.:

THE INFORMATION CONTAINED WITHIN THIS DOCUMENT IS PROPRIETARY TO AAA PRODUCTS AND MAY NOT BE DISCLOSED WITHOUT PRIOR WRITTEN CONSENT