

POSITION GASKET ON END OF VALVE SO
MOUNTING HOLES ALIGN
BOTH ENDS (SIDE 'A' SHOWN)

- NOTES:
 1) ALWAYS GIVE VALVE MODEL, AND PART NUMBER WHEN ORDERING PARTS.
 2) LUBRICATE DETENT BALL, SPRING AND CLEVIS.
 3) MARK NAMEPLATE FOR 500 PSI SERVICE.
 4) USE DOW-55 GREASE ON O-RINGS AND SPOOL.

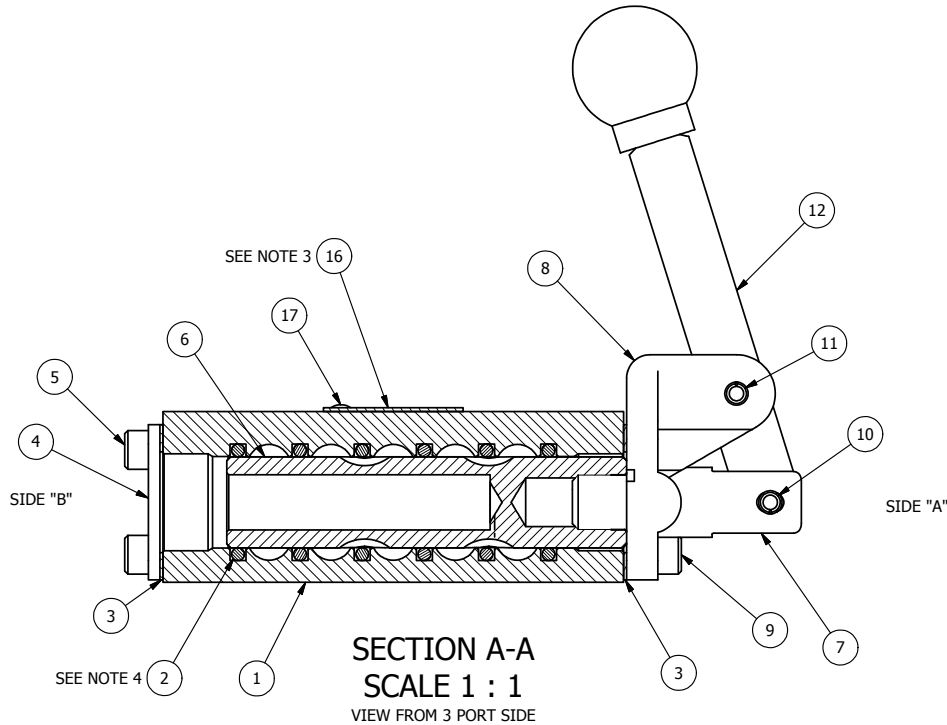

17	2	V-212	SCREW, #2 X 3/16 DRIVE, TYPE U, OVAL HEAD, 316 STAINLESS STEEL
16	1	AN-114	NAME PLATE, BLANK, FOR VALVES WITH SPRINGS OR DETENTS.
15	1	V-14	BALL, CHROME STEEL 3/16 DIA. FOR DETENT
14	1	DS3	SPRING - DETENT, 1/4" & 3/8" VALVE
13	1	V-21	SCREW, 1/4-20 X 3/16 SOCKET SET (CUP POINT)
12	1	HL3-24	HAND LEVER WITH KNOB, 1/4" & 3/8" VALVE
11	1	V-7	PIN, ROLL 3/16 X 11/16 FOR 1/4 THRU 1/2" HAND, FT. & CAM V
10	1	V-48	PIN, ROLL 3/16 X 9/16 ZINC PLATED STEEL FOR 1/4 HAND & FOOT CLEVIS
9	4	V-38	SCREW, 10-24 X 3/4 SHCS, FOR 3/8" CAST END CAP
8	1	HE3-3	END CAP, LEVER, 380 AL, 1/4" & 3/8" VALVE
7	1	HC3-2	CLEVIS - POS. A & C DETENTS, 1/4" & 3/8" VALVE
6	1	S3	SPOOL - STANDARD, 2 POS, CLSD CTR, 1/4" & 3/8" VALVE
5	4	V-37	SCREW, 10-24 X 1/2 SHCS, FOR 1/8" STEEL END CAPS
4	1	SEC3	END CAP, STEEL, ZINC PLT, 1/4" & 3/8" VALVE
3	2	ECG3	GASKET - END CAP, 1/4" & 3/8" VALVE
2	6	V-39	O-RING, STD BODY, VITON, 1/4" & 3/8" VALVES
1	1	B2-2E	BODY - SOLID, PLAIN, NO PILOTS, ANODIZED, 1/4" SIDE PORT VALVE
FLG	QTY	PART NO	DESCRIPTION

LIMITS ON DIMENSIONS
 UNLESS OTHERWISE SPECIFIED
 2- PL DECIMAL ± .01
 3- PL DECIMAL ± .005
 FRACTIONAL ± 1/64
 ANGULAR ± 1/2°



DRAWN: RMcKenna	DATE: 3/3/2009	CHECKED: KWaite	DATE: 5/28/2015
SCALE: 1:1	SHEET: 1 OF 1	RELEASED: HWomack	DATE: 5/28/2015
TITLE: 1/4" SIDE PORT, LEVER, 2 POS, DETENT, LVR RTRN, DOW 55, 500 PSI		PART NO.:	REV.:
		607V	

THE INFORMATION CONTAINED WITHIN THIS DOCUMENT IS PROPRIETARY TO AAA PRODUCTS AND MAY NOT BE DISCLOSED WITHOUT PRIOR WRITTEN CONSENT