

POSITION GASKET ON END OF VALVE SO MOUNTING HOLES ALIGN BOTH ENDS (SIDE 'B' SHOWN)

NOTES:  
1) ALWAYS GIVE VALVE MODEL, AND PART NUMBER WHEN ORDERING PARTS.

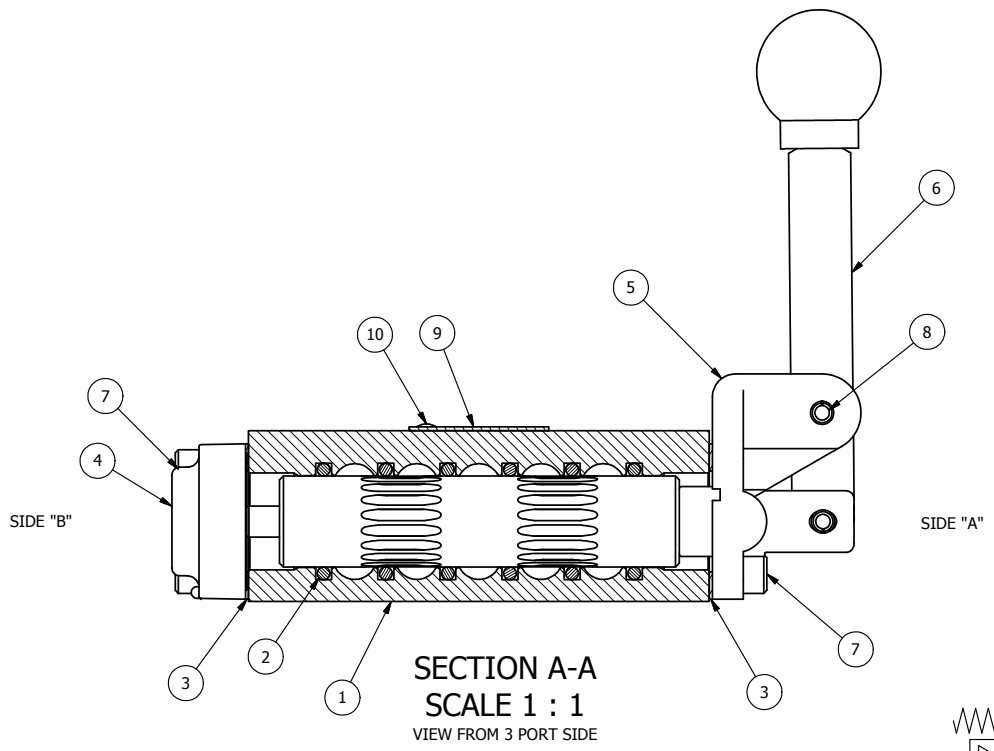

FLG	QTY	PART NO	DESCRIPTION
10	2	V-212	SCREW, #2 X 3/16 DRIVE, TYPE U, OVAL HEAD, 316 STAINLESS STEEL
9	1	AN-114	NAME PLATE, BLANK, FOR VALVES WITH SPRINGS OR DETENTS.
8	1	V-7	PIN, ROLL 3/16 X 11/16 FOR 1/4 THRU 1/2" HAND, FT. & CAM V
7	8	V-38	SCREW, 10-24 X 3/4 SHCS, FOR 3/8" CAST END CAP
6	1	HL3-24	HAND LEVER WITH KNOB, 1/4" & 3/8" VALVE
5	1	HE3-1	END CAP, LEVER, 380 AL, 1/4" & 3/8" VALVE
4	1	AY-HYR3G	ASSY - SPR CTR, FLOAT CTR SPL, LEVER OR TREADLE, PILOT ASST, 1/4 & 3/8 VALVES
3	2	ECG3	GASKET - END CAP, 1/4" & 3/8" VALVE
2	6	V-39	O-RING, STD BODY, VITON, 1/4" & 3/8" VALVES
1	1	B3-2E	BODY - SOLID, PLAIN, NO PILOTS, ANODIZED, 3/8" SIDE PORT VALVE

LIMITS ON DIMENSIONS UNLESS OTHERWISE SPECIFIED		2-PL DECIMAL ± .01 3-PL DECIMAL ± .005 FRACTIONAL ± 1/64 ANGULAR ± 1/2°		<b>AAA PRODUCTS INTERNATIONAL</b> 7114 Harry Hines Blvd Dallas, TX 75235	
DRAWN: RMckenna		DATE: 11/24/2008			CHECKED: KWaite
SCALE: 1 : 1		SHEET: 1 OF 1		RELEASED: HWomack	DATE: 5/28/2015
TITLE: <b>3/8" SIDE PORT, LEVER, 3 POS, SPR CTR, LEVER SHFT, CLSD CTR SPL, PILOT ASSIST RTRN</b>				PART NO.: <b>602VY</b>	REV.: <b>A</b>

NO.	DATE	REVISION
A	3/23/10	REPLACED V-S3 SPR CTR SCREW WITH SHORTER V-S3-DY SPR CTR SCREW.

THE INFORMATION CONTAINED WITHIN THIS DOCUMENT IS PROPRIETARY TO AAA PRODUCTS AND MAY NOT BE DISCLOSED WITHOUT PRIOR WRITTEN CONSENT

P:\Engineering\Inventory Files\Internal Drawings\Valves Assembly\Lever\Special\602VY.dwg