

POSITION GASKET ON END OF VALVE SO MOUNTING HOLES ALIGN, SIDE 'B' ONLY

- NOTES:
 1) ALWAYS GIVE VALVE MODEL AND PART NUMBER WHEN ORDERING PARTS.
 2) USE LOCTITE #242 (BLUE) WITH ALL FASTENERS.

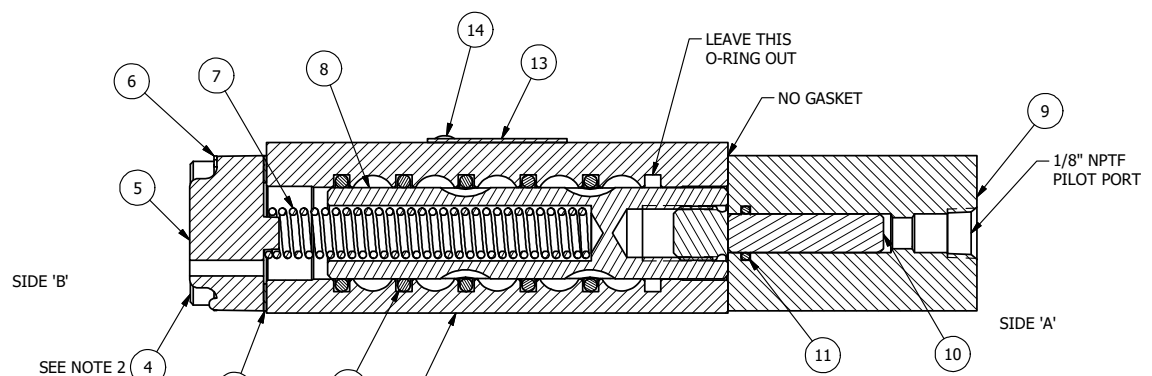

SECTION A-A
 SCALE 1 : 1
 VIEW FROM 3 PORT SIDE

PLG	QTY	PART NO	DESCRIPTION
14	2	V-212	SCREW, 2 X 3/16, DRIVE, TYPE U, OVAL HEAD, 316 SS
13	1	AN-114	NAME PLATE, BLANK, FOR VALVES WITH SPRINGS OR DETENTS.
12	4	V-1	SCREW, 10-24 X 2, SOCKET HEAD CAP
11	1	V-588	O-RING, BUNA-N, 70 DURO, AS-011, (REF 5/16 X 7/16 X 1/16), 3/8" SUBPLATE
10	1	V-587	PIN, 5/16 X 1 1/4" DOWELL PIN FOR 242V.
9	1	PEC3-8	END CAP, PILOT, HIGH PRESSURE HYDRAULIC, BRASS, 1/4" & 3/8" VALVE
8	1	S3-242V	SPOOL ASSY - FLUSH END, 1/4" & 3/8" VALVE
7	1	CS3	SPRING - RETURN, (EXCEPT HO, KO & PO) 1/4" & 3/8" VALVES
6	8	V-667-SS	WASHER, STAR, EXTERNAL TOOTH, #10, STAINLESS STEEL
5	1	SEC3-A	END CAP, VENTED, SPRING BOSS, 380 AL, 1/4" & 3/8" VALVE
4	4	V-38	SCREW, 10-24 X 3/4, SOCKET HEAD CAP
3	1	ECG3	GASKET - END CAP, 1/4" & 3/8" VALVE
2	5	V-39	O-RING, STD BODY, VITON, 1/4" & 3/8" VALVES
1	1	B3-2E	BODY - SOLID, PLAIN, NO PILOTS, ANODIZED, 3/8" SIDE PORT VALVE

LIMITS ON DIMENSIONS UNLESS OTHERWISE SPECIFIED		2-PL DECIMAL ± .01 3-PL DECIMAL ± .005 FRACTIONAL ± 1/64 ANGULAR ± 1/2°		AAA PRODUCTS INTERNATIONAL 7114 Harry Hines Blvd Dallas, TX 75235
DRAWN: RMcKenna	DATE: 2/12/2008	CHECKED: KWaitte	DATE: 5/27/2015	
SCALE: 1 : 1	SHEET: 1 OF 1	RELEASED: HWomack	DATE: 5/27/2015	
TITLE: 3/8" SIDE PORT, SNGL PILOT, 2 POS, SPRING RTRN, 400 PSI TO 3000 PSI HYD PILOT		PART NO.: 477V	REV.: A	

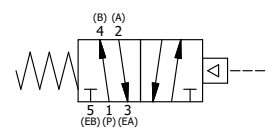

NO.	DATE	REVISION
A	12/5/2017	ADDED NOTE FOR BLUE LOCTITE AND STAR WASHERS.

THE INFORMATION CONTAINED WITHIN THIS DOCUMENT IS PROPRIETARY TO AAA PRODUCTS AND MAY NOT BE DISCLOSED WITHOUT PRIOR WRITTEN CONSENT

D:\Engineering\Inventor Files\Internal Drawings\Valves\Assembly\Pilot\Special\477V.dwg