

POSITION GASKET ON END OF VALVE SO MOUNTING HOLES ALIGN, BOTH ENDS (SIDE 'A' SHOWN)

DOW 55 GREASE

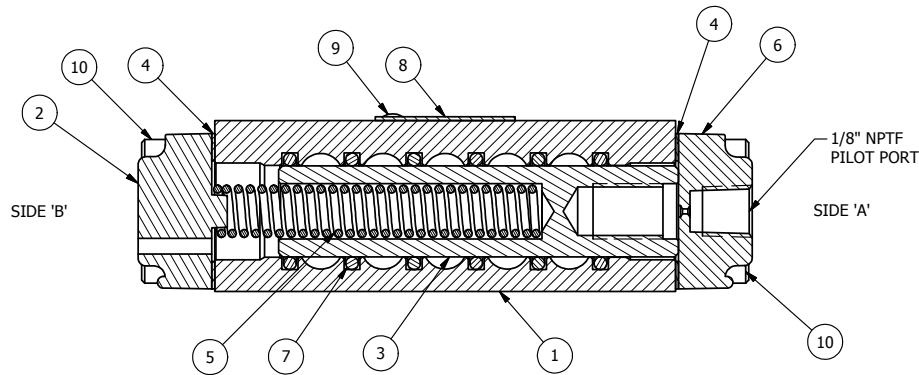

SECTION A-A
SCALE 1 : 1
VIEW FROM 3 PORT SIDE

- NOTES:
 1) ALWAYS GIVE VALVE MODEL AND PART NUMBER WHEN ORDERING PARTS.
 2) USE DOW 55 GREASE FOR LUBRICATING THIS VALVE.
 3) MINIMUM SHIFT PRESSURE - 80 PSI.

FLG	QTY	PART NO	DESCRIPTION
10	8	V-38	SCREW, 10-24 X 3/4 SHCS, FOR 3/8" CAST END CAP
9	2	V-212	SCREW, #2 X 3/16 DRIVE, TYPE U, OVAL HEAD, 316 STAINLESS STEEL
8	1	AN-114	NAME PLATE, BLANK, FOR VALVES WITH SPRINGS OR DETENTS.
7	6	V-39	O-RING, STD BODY, VITON, 1/4" & 3/8" VALVES
6	1	PEC3	END CAP, PILOT, 380 AL, 1/4" & 3/8" VALVE
5	1	SW6991	SPRING - RETURN, 80 PSI, 1/4" & 3/8" VALVES
4	2	ECG3	GASKET - END CAP, 1/4" & 3/8" VALVE
3	1	S3	SPOOL - STANDARD, 2 POS, CLSD CTR, 1/4" & 3/8" VALVE
2	1	SEC3-A	END CAP, VENTED, SPRING BOSS, 380 AL, 1/4" & 3/8" VALVE
1	1	B2-2E	BODY - SOLID, PLAIN, NO PILOTS, ANODIZED, 1/4" SIDE PORT VALVE

LIMITS ON DIMENSIONS UNLESS OTHERWISE SPECIFIED		2-PL DECIMAL ± .01 3-PL DECIMAL ± .005 FRACTIONAL ± 1/64 ANGULAR ± 1/2°		AAA PRODUCTS INTERNATIONAL 7114 Harry Hines Blvd Dallas, TX 75235
DRAWN: RHuffstetter	DATE: 11/3/1999	CHECKED: KWaite	DATE: 5/27/2015	
SCALE: 1 : 1	SHEET: 1 OF 1	RELEASED: HWomack	DATE: 5/27/2015	
TITLE: 1/4" SIDE PORT, SNGL PILOT, 2 POS, SPRING RTRN, 80 PSI SHIFT, DOW 55			PART NO.: 413V	REV.: A

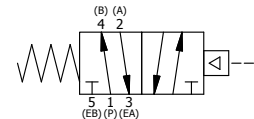

A	NO.	DATE	REVISION
	3/2/06		CHANGED GASKET FROM BG3 TO ECG3.

THE INFORMATION CONTAINED WITHIN THIS DOCUMENT IS PROPRIETARY TO AAA PRODUCTS AND MAY NOT BE DISCLOSED WITHOUT PRIOR WRITTEN CONSENT

P:\Engineering\Inventory Files\Internal Drawings\Valves Assembly\Pilot Special\413V.dwg