

POSITION GASKET ON END OF VALVE SO MOUNTING HOLES ALIGN, BOTH ENDS (SIDE 'A' SHOWN)

Delrin Plunger - ⚠ WARNING: This product can expose you to chemicals including Formaldehyde, which is known to the State of California to cause cancer or birth defects or other reproductive harm. For more information go to www.P65Warnings.ca.gov.

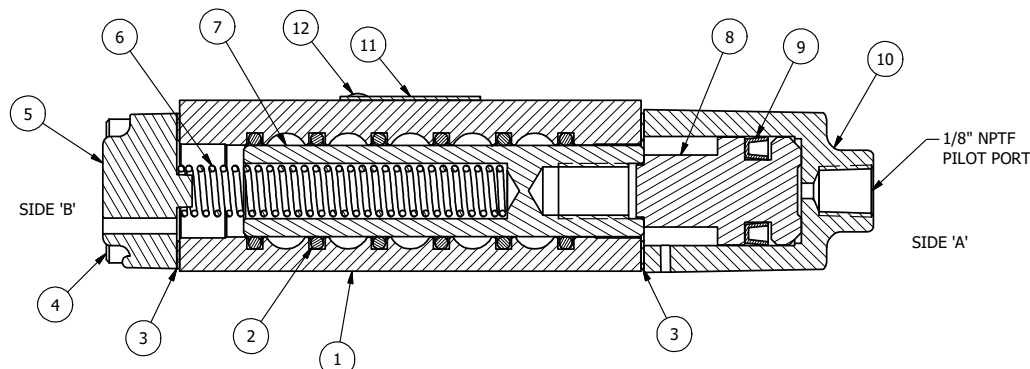

SECTION A-A
SCALE 1 : 1
VIEW FROM 3 PORT SIDE

SEE NOTE 2 ⇨

PLG	QTY	PART NO	DESCRIPTION
12	2	V-212	SCREW, 2 X 3/16, DRIVE, TYPE U, OVAL HEAD, 316 SS
11	1	AN-114	NAME PLATE, BLANK, FOR VALVES WITH SPRINGS OR DETENTS.
10	1	LPEC3	END CAP, PILOT, LOW PRESSURE, 380 AL, 1/4" & 3/8" VALVE
9	1	V-254	U-CUP, NITRILE, 7/8 X 1/2 X 3/16
8	1	MLP2-1	PLUNGER - LOW PRESSURE, OPERATOR
7	1	S3	SPOOL - STANDARD, 2 POS, CLSD CTR, 1/4" & 3/8" VALVE
6	1	CS3-2	SPRING - RETURN, (HO & KO) 1/4" & 3/8" VALVES
5	1	SEC3-A	END CAP, VENTED, SPRING BOSS, 380 AL, 1/4" & 3/8" VALVE
4	8	V-38-SS	SCREW, 10-24 X 3/4, SOCKET HEAD CAP, 18-8 SS
3	2	ECG3	GASKET - END CAP, 1/4" & 3/8" VALVE
2	6	V-39	O-RING, STD BODY, VITON, 1/4" & 3/8" VALVES
1	1	B3-2E	BODY - SOLID, PLAIN, NO PILOTS, ANODIZED, 3/8" SIDE PORT VALVE

- NOTES:
 1) ALWAYS GIVE VALVE MODEL AND PART NUMBER WHEN ORDERING PARTS.
 2) AN MPEC3 CAN BE USED INSTEAD OF AN LPEC3.
 3) 25 PSI MINIMUM SHIFT PRESSURE.

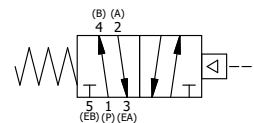

LIMITS ON DIMENSIONS UNLESS OTHERWISE SPECIFIED		2-PL DECIMAL ± .01 3-PL DECIMAL ± .005 FRACTIONAL ± 1/64 ANGULAR ± 1/2°		AAA PRODUCTS INTERNATIONAL 7114 Harry Hines Blvd Dallas, TX 75235
DRAWN: RMcKenna	DATE: 3/31/2016	CHECKED: KWhite	DATE: 3/31/2016	
SCALE: 1 : 1	SHEET: 1 OF 1	RELEASED: HWomack	DATE: 3/31/2016	
TITLE: 3/8" SIDE PORT, SNGL PILOT, 2 POS, SPR RTRN, 25 PSI, STAINLESS FASTENERS			PART NO.: 411V	REV.:

THE INFORMATION CONTAINED WITHIN THIS DOCUMENT IS PROPRIETARY TO AAA PRODUCTS AND MAY NOT BE DISCLOSED WITHOUT PRIOR WRITTEN CONSENT

D:\Engineering\Inventor Files\Internal Drawings\Valves\Assembly\ValveSpecial\411V.dwg