

POSITION GASKET ON END OF VALVE SO MOUNTING HOLES ALIGN, BOTH ENDS (SIDE 'A' SHOWN)

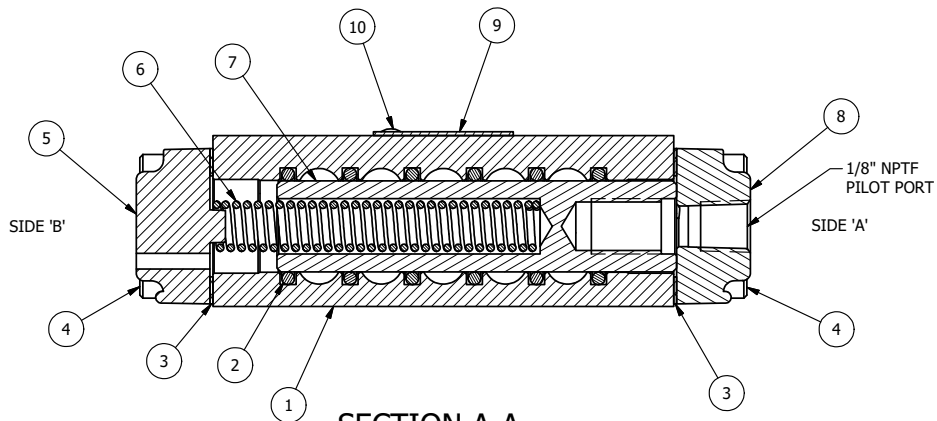

SECTION A-A
SCALE 1 : 1
VIEW FROM 3 PORT SIDE

NOTES:
1) ALWAYS GIVE VALVE MODEL AND PART NUMBER WHEN ORDERING PARTS.

FLG	QTY	PART NO	DESCRIPTION
10	2	V-212	SCREW, #2 X 3/16 DRIVE, TYPE U, OVAL HEAD, 316 STAINLESS STEEL
9	1	AN-114	NAME PLATE, BLANK, FOR VALVES WITH SPRINGS OR DETENTS.
8	1	PEC3-20	END CAP, PILOT, .328 DIA, 380 AL, 1/4" & 3/8" VALVE
7	1	S3	SPOOL - STANDARD, 2 POS, CLSD CTR, 1/4" & 3/8" VALVE
6	1	CS3	SPRING - RETURN, (EXCEPT HO, KO & PO) 1/4" & 3/8" VALVES
5	1	SEC3-A	END CAP, VENTED, SPRING BOSS, 380 AL, 1/4" & 3/8" VALVE
4	8	V-38-SS	SCREW, 10-24 X 3/4 SHCS, 18-8 SS
3	2	ECG3	GASKET - END CAP, 1/4" & 3/8" VALVE
2	6	V-39	O-RING, STD BODY, VITON, 1/4" & 3/8" VALVES
1	1	B3-2E	BODY - SOLID, PLAIN, NO PILOTS, ANODIZED, 3/8" SIDE PORT VALVE

LIMITS ON DIMENSIONS UNLESS OTHERWISE SPECIFIED		2-PL DECIMAL ± .01 3-PL DECIMAL ± .005 FRACTIONAL ± 1/64 ANGULAR ± 1/2°		AAA PRODUCTS INTERNATIONAL 7114 Harry Hines Blvd Dallas, TX 75235	
DRAWN: RHuffstetter		DATE: 4/23/2002			CHECKED: KWaite
SCALE: 1 : 1		SHEET: 1 OF 1		RELEASED: HWomack	DATE: 5/27/2015
TITLE: 3/8" SIDE PORT, SNGL PILOT, 2 POS, SPRING RTRN, SS HDWR, LG ORIFICE				PART NO.: 397V	REV.: B

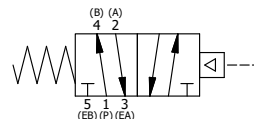

NO.	DATE	REVISION
B	6/28/06	CHANGED GASKET FROM B63 TO ECG3
A	6/2/03	CHANGED FASTENER MATERIAL FROM 18-8

THE INFORMATION CONTAINED WITHIN THIS DOCUMENT IS PROPRIETARY TO AAA PRODUCTS AND MAY NOT BE DISCLOSED WITHOUT PRIOR WRITTEN CONSENT

P:\Engineering\Inventory Files\Internal Drawings\Valves Assembly\Pilot Special\397V.dwg