

POSITON GASKET ON END OF VALVE SO
GASKET COVERES PILOT HOLE
BOTH SIDES (SIDE 'A' SHOWN)

NOTES:

- 1) ALWAYS GIVE VALVE MODEL AND PART NUMBER WHEN ORDERING PARTS.
- 2) LUBRICATE PINLOCK AND SPRING.

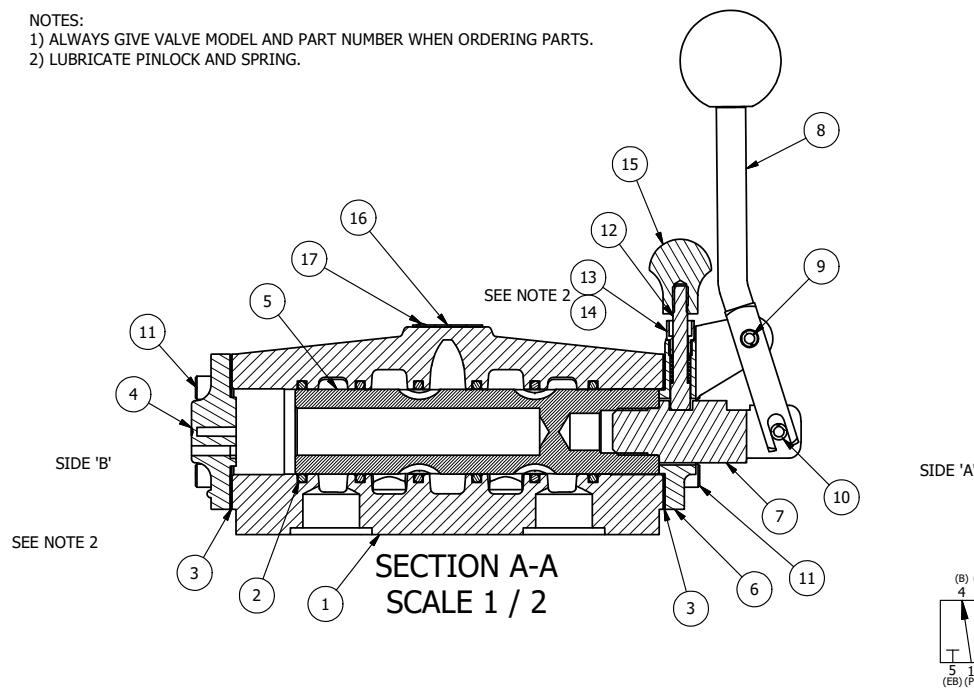

17	2	V-212	SCREW, #2 X 3/16 DRIVE, TYPE U, OVAL HEAD, 316 STAINLESS STEEL
16	1	AN-114	NAME PLATE, BLANK, FOR VALVES WITH SPRINGS OR DETENTS.
15	1	V-570	KNOB, BLACK (BRASS 1/4-20 INSERT), OS OPTION
14	1	V-549	SPRING - PINLOCK, 3/4" & 1" VALVE
13	1	BPR8	BUSHING - PIN LOCK, PIN RETAINER, 3/4" & 1" VALVES
12	1	PPL8	PIN - PIN LOCK, 303 STAINLESS, 3/4" & 1" VALVES
11	8	V-46	SCREW, 1/4-20 X 3/4 SHCS, HOLDS E.C TO 1/2-1" VALVES
10	1	V-51-SS	PIN, ROLL 1/4 X 1 FOR 3/4 & 1" HAND FOOT & CAM VALVES, STAINLESS STEEL
9	1	V-70	PIN, ROLL 1/4 X 1 1/8 FOR 3/4 & 1" HAND AND FOOT VALVES
8	1	HL8-9C	CURVED HAND LEVER WITH KNOB, 3/4" & 1" VALVE
7	1	SC8-365V	CLEVIS - POS. A & C PIN LOCK, 3/4" & 1" VALVE
6	1	FE8-4	END CAP, HAND & FOOT, PIN LOCK, STEEL, NICKEL PLT, 3/4" & 1" VALVES
5	1	S8	SPOOL - STANDARD, 2 POS, CLSD CTR, 3/4" & 1" VALVE
4	1	PEC48-3	END CAP, VENTED, 380 AL, 1/2", 3/4" & 1" VALVES
3	2	ECG48	GASKET - END CAP, 1/2", 3/4" & 1" VALVE
2	6	V-30	O-RING, 1 3/8 X 1 5/8 X 1/8, BUNA-N, N100/70, 70D, ASS68A-220, 3/4" & 1" VALVES
1	1	BPR-1	BODY, 1" SUBPLATE, UPPER PILOTS, ANODIZED
FLG	QTY	PART NO	DESCRIPTION

LIMITS ON DIMENSIONS UNLESS OTHERWISE SPECIFIED		2-PL DECIMAL ± .01 3-PL DECIMAL ± .005 FRACTIONAL ± 1/64 ANGULAR ± 1/2°		AAA PRODUCTS INTERNATIONAL 7114 Harry Hines Blvd Dallas, TX 75235	
DRAWN: RHuffstetter		DATE: 9/29/1999			CHECKED: KWaite
SCALE: 3/4		SHEET: 1 OF 1		RELEASED: HWomack	DATE: 5/27/2015
TITLE: 1" SUBPLATE, LEVER, 2 POS, PINLOCK A & C				PART NO.: 365VP	REV.: A

A	5/7/00	CHANGED PART NUMBER OF V-549 FROM V-547.
NO.	DATE	REVISION

THE INFORMATION CONTAINED WITHIN THIS DOCUMENT IS PROPRIETARY TO AAA PRODUCTS AND MAY NOT BE DISCLOSED WITHOUT PRIOR WRITTEN CONSENT

D:\Engineering\Inventory Files\Internal Drawings\Valves Assembly\Lever\Special\365VP.dwg