

POSITION GASKET ON END OF VALVE SO MOUNTING HOLES ALIGN, BOTH ENDS (SIDE 'A' SHOWN)

NOTES:
1) ALWAYS GIVE VALVE MODEL AND PART NUMBER WHEN ORDERING PARTS.

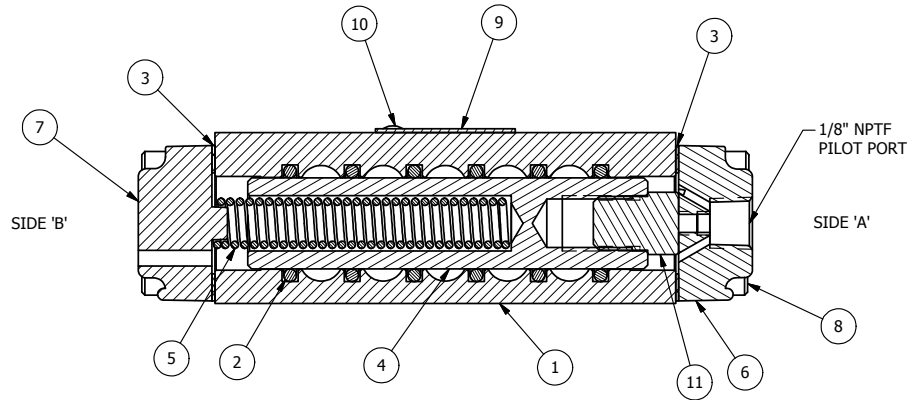

SECTION A-A
SCALE 1 : 1
VIEW FROM 3 PORT SIDE

FLG	QTY	PART NO	DESCRIPTION
11	1	SSC3-1	STUD - SPACER, CENTER POSITION SPACER, 1/4" & 3/8" VALVES
10	2	V-212	SCREW, #2 X 3/16 DRIVE, TYPE U, OVAL HEAD, 316 STAINLESS STEEL
9	1	AN-114	NAME PLATE, BLANK, FOR VALVES WITH SPRINGS OR DETENTS.
8	8	V-38-SS	SCREW, 10-24 X 3/4 SHCS, 18-8 SS
7	1	SEC3-A	END CAP, VENTED, SPRING BOSS, 380 AL, 1/4" & 3/8" VALVE
6	1	DPEC3	ENDCAP, PILOT, SPR CTR, 380 AL, 1/4" & 3/8" VALVE
5	1	CS3	SPRING - RETURN, (EXCEPT HO, KO & PO) 1/4" & 3/8" VALVES
4	1	S3	SPOOL - STANDARD, 2 POS, CLSD CTR, 1/4" & 3/8" VALVE
3	2	ECG3	GASKET - END CAP, 1/4" & 3/8" VALVE
2	6	V-39	O-RING, STD BODY, VITON, 1/4" & 3/8" VALVES
1	1	B2-2E	BODY - SOLID, PLAIN, NO PILOTS, ANODIZED, 1/4" SIDE PORT VALVE

LIMITS ON DIMENSIONS
UNLESS OTHERWISE SPECIFIED
2-PL DECIMAL ± .01
3-PL DECIMAL ± .005
FRACTIONAL ± 1/64
ANGULAR ± 1/2°



DRAWN: RHuffstetter DATE: 11/2/1999 CHECKED: KWaite DATE: 5/27/2015
SCALE: 1 : 1 SHEET: 1 OF 1 RELEASED: HWomack DATE: 5/27/2015

TITLE:
1/4" SIDE PORT, SNGL PILOT, 2 POS,
SPRING RTRN, SS HRDWR, HALF SHFT
PART NO.:
363V
REV.:
A

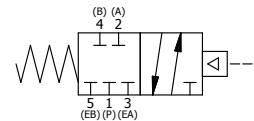

A	NO.	DATE	REVISION
1	1/4/2013	CHANGED SCREWS FROM V-500 TO V-38-SS.	

THE INFORMATION CONTAINED WITHIN THIS DOCUMENT IS PROPRIETARY TO AAA PRODUCTS AND MAY NOT BE DISCLOSED WITHOUT PRIOR WRITTEN CONSENT