

POSITON GASKET ON END OF VALVE SO GASKET COVERES PILOT HOLE BOTH SIDES (SIDE 'A' SHOWN)

NOTES:
 1) ALWAYS GIVE VALVE MODEL AND PART NUMBER WHEN ORDERING PARTS.
 2) LUBRICATE DETENT BALL, SPRING AND CLEVIS.

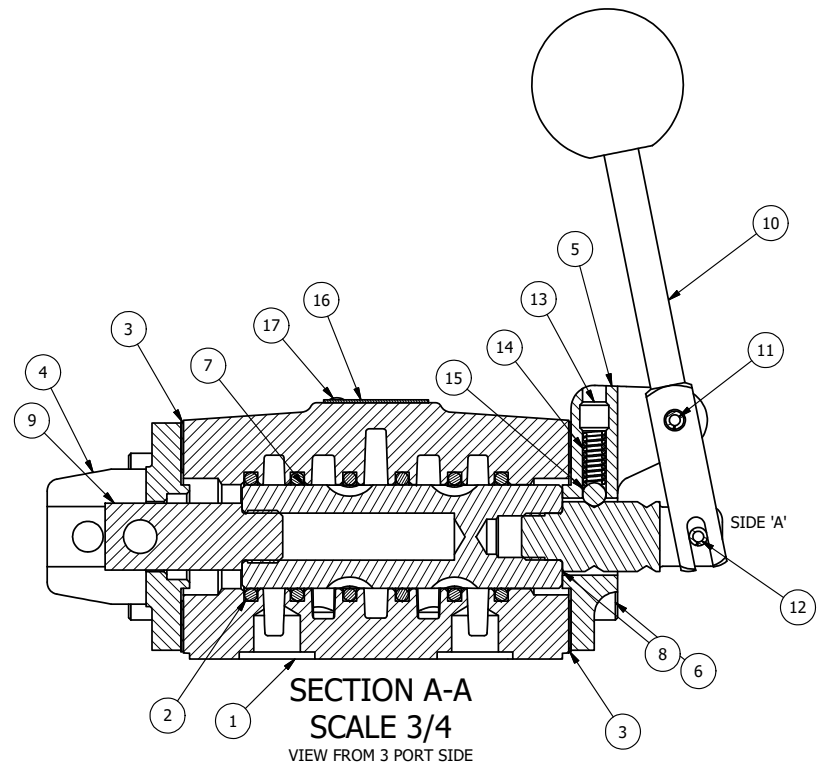

SECTION A-A
 SCALE 3/4
 VIEW FROM 3 PORT SIDE

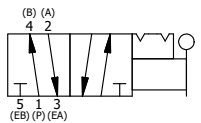

FLG	QTY	PART NO	DESCRIPTION
17	2	V-212	SCREW, #2 X 3/16 DRIVE, TYPE U, OVAL HEAD, 316 STAINLESS STEEL
16	1	AN-114	NAME PLATE, BLANK, FOR VALVES WITH SPRINGS OR DETENTS.
15	1	V-4	BALL, CHROME STEEL 1/4 DIA. FOR DETENT
14	1	DS48	SPRING - DETENT, 1/2", 3/4" & 1" VALVE
13	1	V-8	SCREW, 5/16-18 X 5/16 SOCKET SET-CUP POINT, FOR DETENT ASSY 1/2&1".
12	1	V-7	PIN, ROLL 3/16 X 11/16 FOR 1/4 THRU 1/2" HAND, FT. & CAM V
11	1	V-10	PIN, ROLL 3/16 X 7/8 FOR 1/2" HAND AND FOOT VALVE
10	1	HL4-9	HAND LEVER ASSEMBLY, 1/2" VALVE
9	1	LOS4-2	STUD - REAR LOCKOUT, POSITION A & C, 1/2" VALVE
8	1	SC4-2	CLEVIS - POS. A & C DETENT, 1/2" VALVE
7	1	S4-LO	SPOOL - REAR LOCKOUT, 1/2" VALVE
6	8	V-46	SCREW, 1/4-20 X 3/4 SHCS, HOLDS E.C TO 1/2-1" VALVES
5	1	FE4-3	END CAP - HAND & FOOT, DETENT, 380 AL, 1/2" VALVE
4	1	CEC4-1LO	ENDCAP - LOCK OUT, 6061-T6 AL, 1/2" VALVE
3	2	ECG48	GASKET - END CAP, 1/2", 3/4" & 1" VALVE
2	6	V-6	O-RING, 1 1/8 X 1 3/8 X 1/8, BUNA-N, N100/70, 70D, ASS68A-216, 1/2" VALVES
1	1	BP4-1	BODY, 1/2" SUBPLATE, UPPER PILOTS, ANODIZED

LIMITS ON DIMENSIONS UNLESS OTHERWISE SPECIFIED		2-PL DECIMAL ± .01 3-PL DECIMAL ± .005 FRACTIONAL ± 1/64 ANGULAR ± 1/2°		AAA PRODUCTS INTERNATIONAL 7114 Harry Hines Blvd Dallas, TX 75235
DRAWN: RHuffstetter	DATE: 11/13/1998	CHECKED: KWaite	DATE: 5/28/2015	
SCALE: 3/4	SHEET: 1 OF 1	RELEASED: HWomack	DATE: 5/28/2015	
TITLE: 1/2" SUBPLATE, LEVER, 2 POS, DETENT, LEVER RTRN, REAR LOCKOUT POS A & C			PART NO.: 361VP	REV.:

THE INFORMATION CONTAINED WITHIN THIS DOCUMENT IS PROPRIETARY TO AAA PRODUCTS AND MAY NOT BE DISCLOSED WITHOUT PRIOR WRITTEN CONSENT

D:\Engineering\Inventory Files\Internal Drawings\Valves Assembly\Levers\Special\361VP.dwg