

POSITION GASKET ON END OF VALVE SO MOUNTING HOLES ALIGN BOTH ENDS (SIDE 'A' SHOWN)

NOTES:
1) ALWAYS GIVE VALVE MODEL, AND PART NUMBER WHEN ORDERING PARTS.

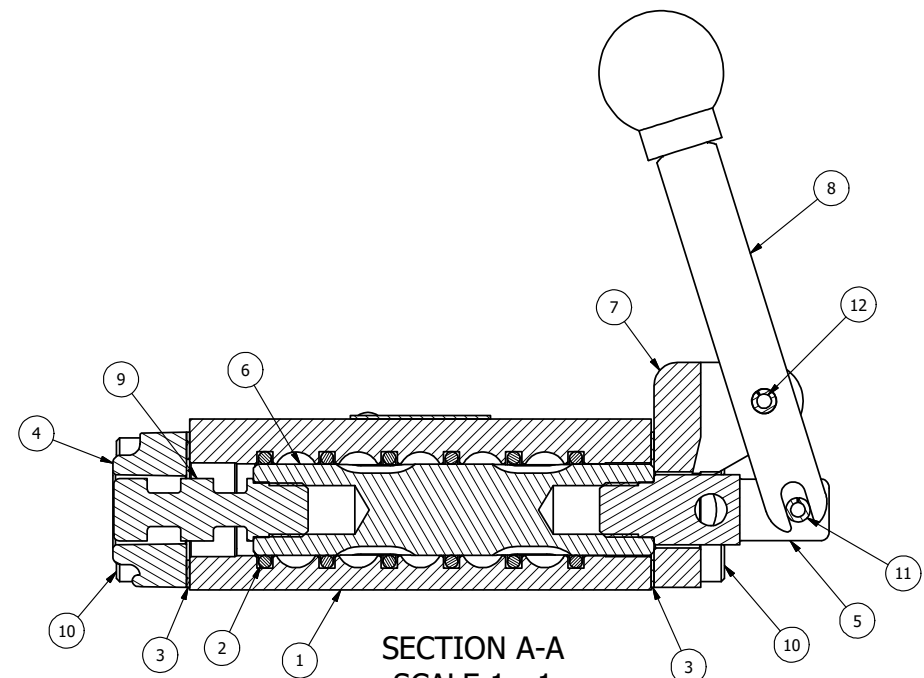

SECTION A-A
SCALE 1 : 1
VIEW FROM 3 PORT SIDE

FLG	QTY	PART NO	DESCRIPTION
17	2	V-212	SCREW, 2 X 3/16, DRIVE, TYPE U, OVAL HEAD, 316 SS
16	1	AN-114	NAME PLATE, BLANK, FOR VALVES WITH SPRINGS OR DETENTS.
15	1	V-175	KNOB, BLACK, (BRASS 10-32 INSERT), 3/4 DIA BALL, PIN LOCK
14	1	BBS-1	SPRING - BUTTON BLEEDER, 1/8" NPTF
13	1	V-315	PIN - PIN LOCK, STEEL, 1/4" & 3/8" VALVE
12	1	V-7	PIN, ROLL 3/16 X 11/16 FOR 1/4 THRU 1/2" HAND, FT. & CAM V
11	1	V-48	PIN, ROLL 3/16 X 9/16 ZINC PLATED STEEL
10	8	V-38	SCREW, 10-24 X 3/4, SOCKET HEAD CAP
9	1	PBS3-12	STUD - POS A & C PINLOCK, 1/4" & 3/8" VALVE
8	1	HL3-24	HAND LEVER WITH KNOB, 1/4" & 3/8" VALVE
7	1	HE3-1LO	END CAP, LEVER, LOCK OUT, 380 AL, 1/4" & 3/8" VALVE
6	1	S3RG	SPOOL - SOLID, 'G', 2 POS, FLOAT CTR, 1/4" & 3/8" VALVE
5	1	HC3-1LOB	CLEVIS - POS. B LOCKOUT, 1/4" & 3/8" VALVE
4	1	PEC3-2PLL	END CAP, PALM, PIN LOCK, LEFT, 380 AL, 1/4" & 3/8" VALVE
3	2	ECG3	GASKET - END CAP, 1/4" & 3/8" VALVE
2	6	V-39	O-RING, STD BODY, VITON, 1/4" & 3/8" VALVES
1	1	B2-350V-LP	BODY - SOLID, PLAIN, LESS PLATE, 1/4" BSPT VALVE
FLG	QTY	PART NO	DESCRIPTION

LIMITS ON DIMENSIONS UNLESS OTHERWISE SPECIFIED		2-PL DECIMAL ± .01 3-PL DECIMAL ± .005 FRACTIONAL ± 1/64 ANGULAR ± 1/2°		AAA PRODUCTS INTERNATIONAL 7114 Harry Hines Blvd Dallas, TX 75235
DRAWN: RHuffstetter	DATE: 9/12/2001	CHECKED: KWaite	DATE: 5/27/2015	
SCALE: 1 : 1	SHEET: 1 OF 1	RELEASED: HWomack	DATE: 5/27/2015	
TITLE: 1/4" BSPT, LEVER, 2 POS, PIN LOCK, FLOAT CTR SPL, LOCK OUT POS B		PART NO.:	350V	REV.: B

B	1/8/2019	ADDED NAMETAG.
A	7/19/2014	CHANGED TO LP BODY FOR COST.
NO.	DATE	REVISION

THE INFORMATION CONTAINED WITHIN THIS DOCUMENT IS PROPRIETARY TO AAA PRODUCTS AND MAY NOT BE DISCLOSED WITHOUT PRIOR WRITTEN CONSENT

C:\Engineering\Inventor Files\Internal Drawings\Valves\Assembly Level\Special\350V.dwg