

POSITION GASKET ON END OF VALVE SO MOUNTING HOLES ALIGN, BOTH ENDS (SIDE 'A' SHOWN)

- NOTES:
 1) ALWAYS GIVE VALVE MODEL AND PART NUMBER WHEN ORDERING PARTS.
 2) INSERT AY-PYS3 LINKAGE ASSEMBLY INTO S3 SPOOL TO A GAP OF 11/64.
 3) MINIMUM SHIFT PRESSURE OF 7 PSI ON PISTON PILOT PORTS.

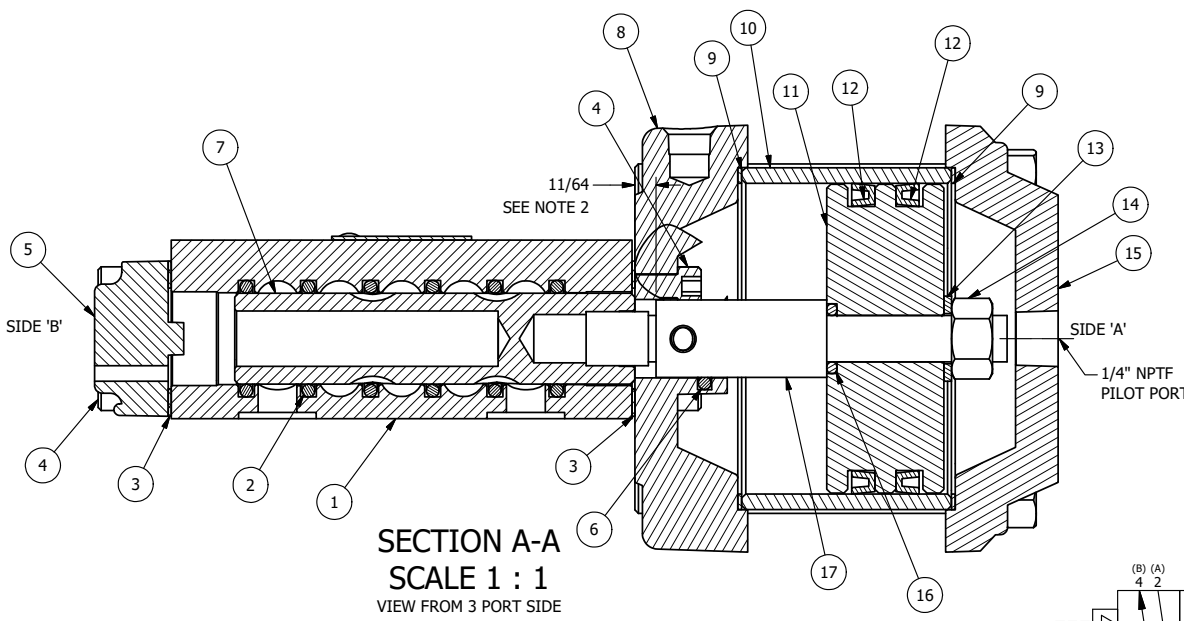

SECTION A-A
 SCALE 1 : 1
 VIEW FROM 3 PORT SIDE

23	1	SPK-3	KIT - SUBPLATE MOUNTING, 3/8" SUBPLATE VALVES
22	4	V-242	SCREW, 5/16-18 X 3, HEX HEAD, PLATED
21	4	V-104-SS	STAR WASHER 5/16" STAINLESS STEEL
20	4	V-105-SS	NUT, 5/16-18, HEX, STAINLESS STEEL
19	2	V-212	SCREW, #2 X 3/16 DRIVE, TYPE U, OVAL HEAD, STAINLESS STEEL
18	1	AN-115	NAMEPLATE, BLANK, FOR HE,KE,RR,D,CR,PP,SR,SS VALVES
17	1	AY-PYS3	PISTON OPERATOR LINKAGE ASSEMBLY 1/4" & 3/8" VALVES
16	1	V-89	O-RING, BUNA-N, 70 DURO, AS-110, (REF 3/8 X 9/16 X 3/32), 1" & 2" SUBPLATE PILOT
15	1	PBEC3	PISTON - ENCAP, BLIND, 1/4" & 3/8" VALVE
14	1	V-227	NUT, 3/8-16, HEX, PLATED
13	1	V-270	WASHER FLAT 3/8" CADMIUM PLATED FOR ALL PISTON OPERATORS
12	2	V-115	U-CUP, 2-1/2 X 2-1/8 X 3/16, NITRILE
11	1	YP3-A	2 1/2" PISTON - 2 POS., 1/4" & 3/8" VALVE
10	1	BRY3-1	BARREL, SPR CTR, 1/4" & 3/8" PISTON VALVE
9	2	V-165	GASKET - PISTON BARREL, 1/4" & 3/8" VALVE
8	1	PRCY3	PISTON - 3 POS., ROD END, 1/4" & 3/8" VALVE
7	1	S3	SPOOL - STANDARD, 2 POS, CLSD CTR, 1/4" & 3/8" VALVE
6	1	V-110	O-RING, BUNA-N, 70 DURO, AS-114, (REF 5/8 X 13/16 X 3/32), 1/4" SLEEVE, 1/2" SUB, STACK
5	1	SEC3-A	END CAP, VENTED, SPRING BOSS, 380 AL, 1/4" & 3/8" VALVE
4	8	V-38	SCREW, 10-24 X 3/4, SOCKET HEAD CAP
3	2	ECG3	GASKET - END CAP, 1/4" & 3/8" VALVE
2	6	V-39	O-RING, VITON, STD BODY, 1/4" & 3/8" VALVES
1	1	BP3-2E	BODY - SOLID, PLAIN, NO PILOTS, ANODIZED, 3/8" SUBPLATE VALVE
FLG	QTY	PART NO	DESCRIPTION

LIMITS ON DIMENSIONS
 UNLESS OTHERWISE SPECIFIED
 2-PL DECIMAL ± .01
 3-PL DECIMAL ± .005
 FRACTIONAL ± 1/64
 ANGULAR ± 1/2°



DRAWN: RMckenna	DATE: 9/26/2014	CHECKED: KWaite	DATE: 3/26/2015
SCALE: 1 : 1	SHEET: 1 OF 1	RELEASED: HWomack	DATE: 3/26/2015
TITLE: 3/8" SUBPLATE, PISTON, 2 POS, FRICTION POS, PISTON RTRN		PART NO.: PP3P	REV.:

THE INFORMATION CONTAINED WITHIN THIS DOCUMENT IS PROPRIETARY TO AAA PRODUCTS AND MAY NOT BE DISCLOSED WITHOUT PRIOR WRITTEN CONSENT