

POSITION GASKET ON END OF VALVE TO SEAL PILOT HOLE IF PRESENT, BOTH SIDES (SIDE 'B' SHOWN)

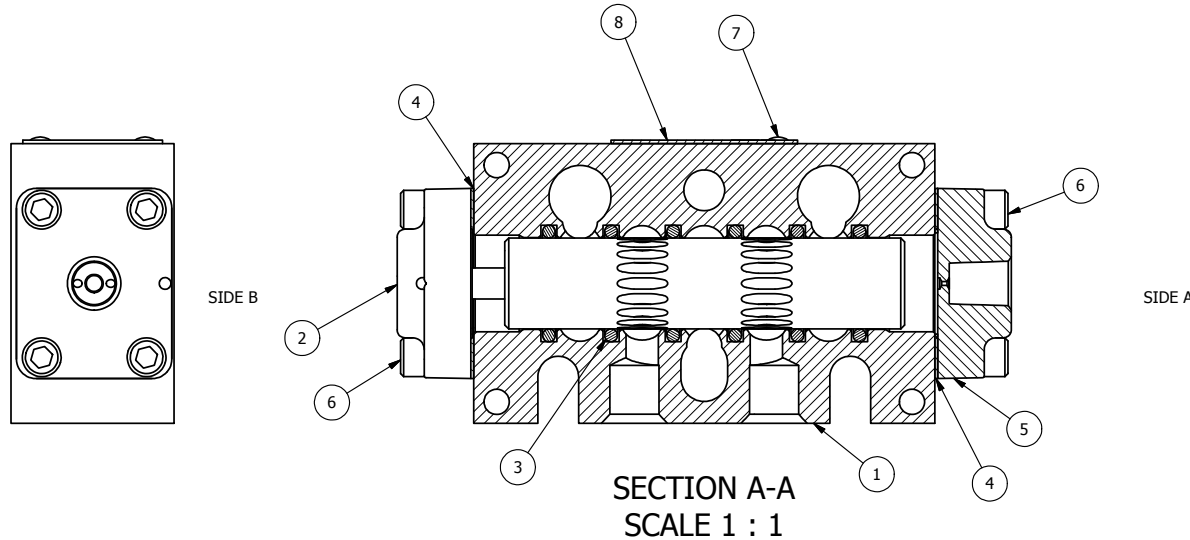

FLG	QTY	PART NO	DESCRIPTION
9	3	V-110	O-RING, 5/8 X 13/16 X 3/32 BUNA 70 D. FOR 1/4 SLEEVE VALVES & STACKING MANIFOLD
8	1	AN-114	NAME PLATE, BLANK, FOR VALVES WITH SPRINGS OR DETENTS.
7	2	V-212	SCREW, #2 X 3/16 DRIVE, TYPE U, OVAL HEAD, 316 STAINLESS STEEL
6	8	V-38	SCREW, 10-24 X 3/4 SHCS, FOR 3/8" CAST END CAP
5	1	PEC3	END CAP, PILOT, 300 AL, 1/4" & 3/8" VALVE
4	2	ECG3	GASKET - END CAP, 1/4" & 3/8" VALVE
3	6	V-39	O-RING, STD BODY, VITON, 1/4" & 3/8" VALVES
2	1	AY-RY3	SPRING CENTER SPOOL ASSY, REMOTE PILOT, 1/4 & 3/8 VALVES
1	1	B2-10E	FINISHED - SOLID BODY, UPPER PILOTS, 1/4" STACKING VALVE

NOTES:
1) ALWAYS GIVE VALVE MODEL AND PART NUMBER WHEN ORDERING PARTS.

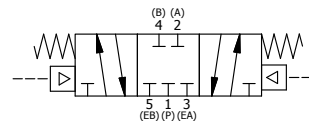

LIMITS ON DIMENSIONS UNLESS OTHERWISE SPECIFIED		2-PL DECIMAL ± .01 3-PL DECIMAL ± .005 FRACTIONAL ± 1/64 ANGULAR ± 1/2°		AAA PRODUCTS INTERNATIONAL 7114 Harry Hines Blvd Dallas, TX 75235	
DRAWN: RHuffstetter		DATE: 3/11/2002			CHECKED: KWaite
SCALE: 1:1		SHEET: 1 OF 1		RELEASED: HWomack	DATE: 9/29/2013
TITLE: 1/4" STACK, DBL PILOT, 3 POS, SPR CTR, PILOT SHFT, CLSD CTR SPL				PART NO.: BRY2	REV.: C

NO.	DATE	REVISION
C	1/7/2014	RE-ORIENTED ENDCAP TO USE PILOTED BODY.
B	10/17/06	CHANGED GASKET FROM BG3 TO ECG3.
A	7/20/05	CHANGED GASKET FROM NEG3 TO BG3.

THE INFORMATION CONTAINED WITHIN THIS DOCUMENT IS PROPRIETARY TO AAA PRODUCTS AND MAY NOT BE DISCLOSED WITHOUT PRIOR WRITTEN CONSENT

P:\Engineering\Inventory Files\Internal Drawings\Valves Assembly\Pilot RV (BRY2).dwt