

POSITION GASKET ON END OF VALVE TO SEAL PILOT HOLE IF PRESENT, BOTH SIDES (SIDE 'B' SHOWN)

NOTES:

- 1) ALWAYS GIVE VALVE MODEL AND PART NUMBER WHEN ORDERING PARTS.
- 2) LUBRICATE DETENT BALL, SPRING AND STUD.

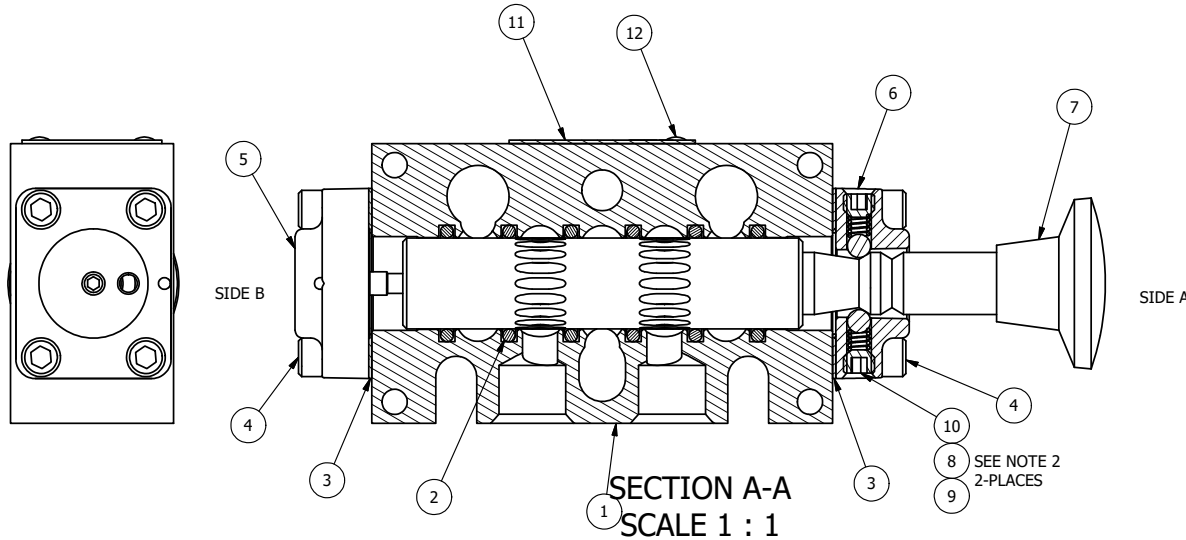

FLG	QTY	PART NO	DESCRIPTION
13	3	V-110	O-RING, BUNA-N, 70 DURO, AS-114, (REF 5/8 X 13/16 X 3/32), 1/4" SLEEVE, 1/2" SUB, STACK
12	2	V-212	SCREW, #2 X 3/16 DRIVE, TYPE U, OVAL HEAD, STAINLESS STEEL
11	1	AN-114	NAMEPLATE, BLANK, FOR VALVES WITH SPRINGS OR DETENTS
10	2	V-21	SCREW, 1/4-20 X 3/16, SOCKET SET, CUP POINT
9	2	DS3	SPRING - DETENT, 1/4" & 3/8" VALVE
8	2	V-14	BALL, CHROME STEEL 3/16 DIA, GRADE 25, FOR DETENT
7	1	V-520	KNOB, BLACK (BRASS 5/16 -18 INSERT), 5/16-18 X 7/16 THREAD, 1-3/8 DIA X 7/8 HEIGHT
6	1	PEC3-3DD	END CAP, PALM, DOUBLE DETENT, 380 AL, 1/4" & 3/8" VALVE
5	1	AY-KX3	ASSY - DETENT A, SPR CTR FROM C, CLSD CTR SPL, PALM, 1/4" & 3/8" VALVES
4	8	V-38	SCREW, 10-24 X 3/4, SOCKET HEAD CAP
3	2	ECG3	GASKET - END CAP, 1/4" & 3/8" VALVE
2	6	V-39	O-RING, VITON, STD BODY, 1/4" & 3/8" VALVES
1	1	B3-10E	FINISHED - SOLID BODY, UPPER PILOTS, 3/8" STACKING VALVE

LIMITS ON DIMENSIONS
UNLESS OTHERWISE SPECIFIED

2-PL DECIMAL ± .01
3-PL DECIMAL ± .005
FRACTIONAL ± 1/64
ANGULAR ± 1/2°



DRAWN: RMckenna DATE: 9/19/2016

CHECKED: KWaitte DATE: 9/19/2016

SCALE: 1:1 SHEET: 1 OF 1

RELEASED: HWomack DATE: 9/19/2016

TITLE:
3/8" STACK, PALM, 3 POS,
DETENT A, SPR CTR FROM C,
CLSD CTR SPL

PART NO.:
BKX3

REV.:

