

POSITION GASKET ON END OF VALVE SO MOUNTING HOLES ALIGN, BOTH ENDS (SIDE 'A' SHOWN)

NOTES:
 1) ALWAYS GIVE VALVE MODEL AND PART NUMBER WHEN ORDERING PARTS.
 2) LUBRICATE DETENT BALL, SPRING AND STUD.

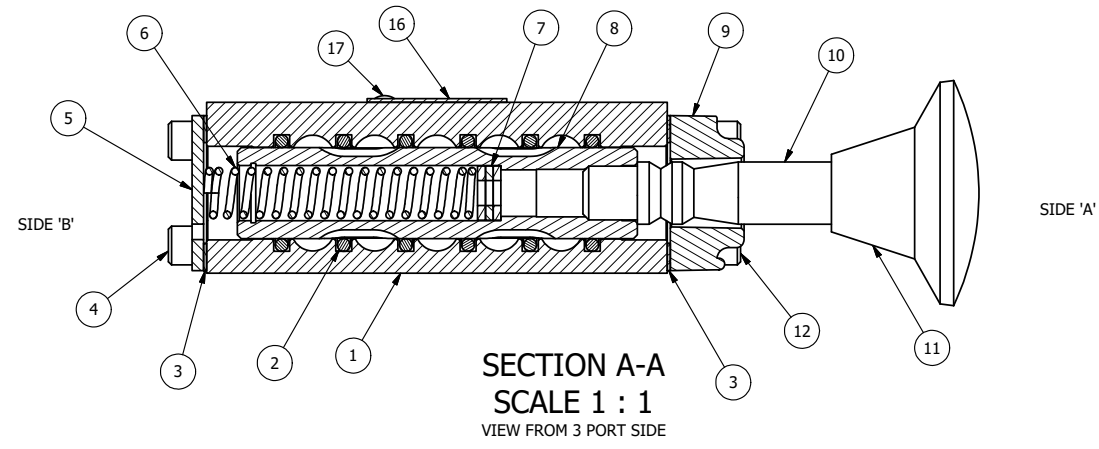

17	2	V-212	SCREW, #2 X 3/16 DRIVE, TYPE U, OVAL HEAD, STAINLESS STEEL
16	1	AN-114	NAMEPLATE, BLANK, FOR VALVES WITH SPRINGS OR DETENTS
15	2	V-14	BALL, CHROME STEEL 3/16 DIA, GRADE 25, FOR DETENT
14	2	DS3	SPRING - DETENT, 1/4" & 3/8" VALVE
13	2	V-21	SCREW, 1/4-20 X 3/16, SOCKET SET, CUP POINT
12	4	V-38	SCREW, 10-24 X 3/4, SOCKET HEAD CAP
11	1	V-543	KNOB, RED (BRASS 5/16-18 INSERT), PALM, 1 13/16 DIA, PUSH/PULL, 1/4" & 3/8" VALVES
10	1	PBS3-189	STUD - PALM, 189 ACTION, 1/4" & 3/8" VALVES
9	1	PEC3-3DD	END CAP, PALM, DOUBLE DETENT, 380 AL, 1/4" & 3/8" VALVE
8	1	SSH3G	SPOOL - 'G', 3 POS, FLOAT CTR, 1/4" & 3/8" VALVE
7	3	V-43	WASHER - SPRING CTR, 302/304 STAINLESS STEEL, 1/4" & 3/8" VALVES
6	1	CS3-1	SPRING - CENTERING, 1/4" & 3/8" VALVES
5	1	SEC3	END CAP, 304 STAINLESS STEEL, 1/4" & 3/8" VALVE
4	4	V-37	SCREW, 10-24 X 1/2, SOCKET HEAD CAP
3	2	ECG3	GASKET - END CAP, 1/4" & 3/8" VALVE
2	6	V-39	O-RING, VITON, STD BODY, 1/4" & 3/8" VALVES
1	1	B2-2E	BODY - SOLID, PLAIN, NO PILOTS, ANODIZED, 1/4" SIDE PORT VALVE
FLG	QTY	PART NO	DESCRIPTION

LIMITS ON DIMENSIONS UNLESS OTHERWISE SPECIFIED		2-PL DECIMAL ± .01 3-PL DECIMAL ± .005 FRACTIONAL ± 1/64 ANGULAR ± 1/2°		AAA PRODUCTS INTERNATIONAL 7114 Harry Hines Blvd Dallas, TX 75235
DRAWN: RMckenna	DATE: 9/14/2016	CHECKED: KWaite	DATE: 9/14/2016	
SCALE: 1 : 1	SHEET: 1 OF 1	RELEASED: HWomack	DATE: 9/14/2016	
TITLE: 1/4" SIDE PORT, PALM, 3 POS, DETENT C, SPR CTR FROM A, FLOAT CTR SPL, RED KNOB			PART NO.: KW2GJ	REV.:

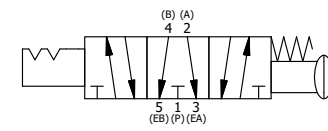

THE INFORMATION CONTAINED WITHIN THIS DOCUMENT IS PROPRIETARY TO AAA PRODUCTS AND MAY NOT BE DISCLOSED WITHOUT PRIOR WRITTEN CONSENT

P:\Engineering\Product\Valve Assembly\Palm KW2GJ.dwg