

POSITION GASKET ON END OF VALVE TO SEAL PILOT HOLE IF PRESENT, BOTH SIDES (SIDE 'B' SHOWN)

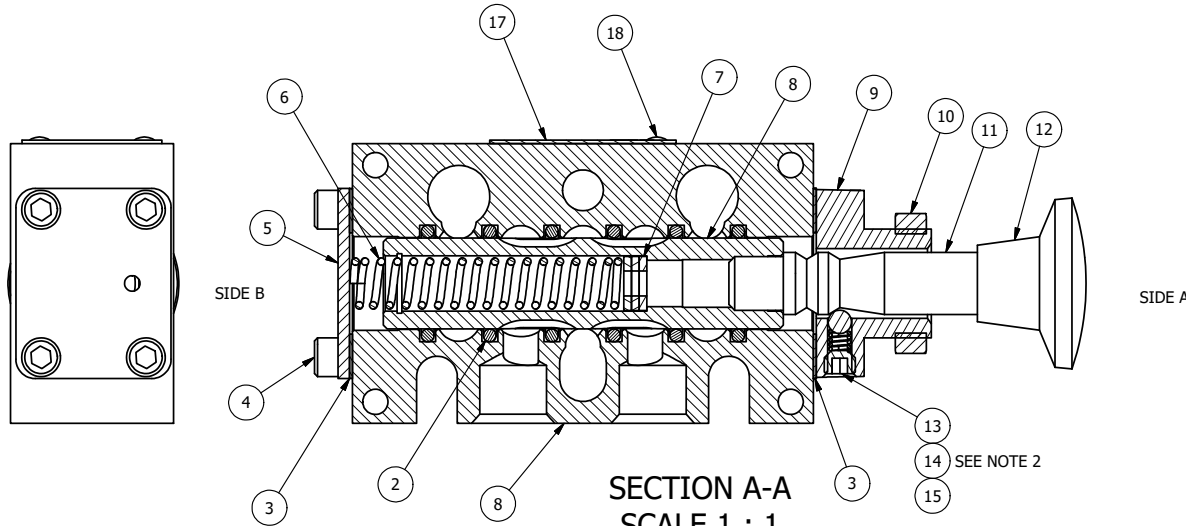

| | | | |
|-----|-----|----------|---|
| 19 | 3 | V-110 | O-RING, BUNA-N, 70 DURO, AS-114, (REF 5/8 X 13/16 X 3/32), 1/4" SLEEVE, 1/2" SUB, STACK |
| 18 | 2 | V-212 | SCREW, #2 X 3/16 DRIVE, TYPE U, OVAL HEAD, STAINLESS STEEL |
| 17 | 1 | AN-114 | NAMEPLATE, BLANK, FOR VALVES WITH SPRINGS OR DETENTS |
| 16 | 4 | V-162 | SCREW, 10-24 X 5/8, SOCKET HEAD CAP |
| 15 | 1 | V-14 | BALL, CHROME STEEL 3/16 DIA, GRADE 25, FOR DETENT |
| 14 | 1 | DS3 | SPRING - DETENT, 1/4" & 3/8" VALVE |
| 13 | 1 | V-21 | SCREW, 1/4-20 X 3/16, SOCKET SET, CUP POINT |
| 12 | 1 | V-520 | KNOB, BLACK (BRASS 5/16 -18 INSERT), 5/16-18 X 7/16 THREAD, 1-3/8 DIA X 7/8 HEIGHT |
| 11 | 1 | PBS3-189 | STUD - PALM, 189 ACTION, 1/4" & 3/8" VALVES |
| 10 | 1 | V-501 | NUT - PANEL MOUNT, YELLOW BRASS, 1/4" & 3/8" VALVE |
| 9 | 1 | PEC3-12 | END CAP, PALM, PANEL MNT, DETENT, 303 STAINLESS STEEL, 1/4" & 3/8" VALVE |
| 8 | 1 | B3-10E | FINISHED - SOLID BODY, UPPER PILOTS, 3/8" STACKING VALVE |
| 7 | 3 | V-43 | WASHER - SPRING CTR, 302/304 STAINLESS STEEL, 1/4" & 3/8" VALVES |
| 7 | 1 | SSH3D | SPOOL - 'D', 3 POS, REGEN CTR, 1/4" & 3/8" VALVE |
| 6 | 1 | CS3-1 | SPRING - CENTERING, 1/4" & 3/8" VALVES |
| 5 | 1 | SEC3 | END CAP, 304 STAINLESS STEEL, 1/4" & 3/8" VALVE |
| 4 | 4 | V-37 | SCREW, 10-24 X 1/2, SOCKET HEAD CAP |
| 3 | 2 | ECG3 | GASKET - END CAP, 1/4" & 3/8" VALVE |
| 2 | 6 | V-39 | O-RING, VITON, STD BODY, 1/4" & 3/8" VALVES |
| FLG | QTY | PART NO | DESCRIPTION |

- NOTES:
 1) ALWAYS GIVE VALVE MODEL AND PART NUMBER WHEN ORDERING PARTS.
 2) LUBRICATE DETENT BALL, SPRING AND STUD.

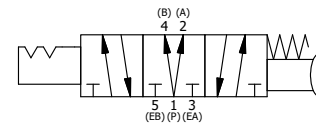

| | | | |
|---|--|--|-----------------|
| LIMITS ON DIMENSIONS UNLESS OTHERWISE SPECIFIED | 2-PL DECIMAL ± .01 3-PL DECIMAL ± .005 FRACTIONAL ± 1/64 ANGULAR ± 1/2° | AAA PRODUCTS INTERNATIONAL 7114 Harry Hines Blvd Dallas, TX 75235 | |
| DRAWN: RMckenna | DATE: 5/2/2022 | | CHECKED: KWaite |
| SCALE: 1:1 | SHEET: 1 OF 1 | RELEASED: HWomack | DATE: 5/2/2022 |
| TITLE: 3/8" STACK, PALM, 3 POS, DETENT C, SPR CTR FROM A, REGEN CTR SPL, PANEL MNT | | PART NO.: BKW3DR | REV.: |

THE INFORMATION CONTAINED WITHIN THIS DOCUMENT IS PROPRIETARY TO AAA PRODUCTS AND MAY NOT BE DISCLOSED WITHOUT PRIOR WRITTEN CONSENT