

POSITION GASKET ON END OF VALVE TO SEAL PILOT HOLE IF PRESENT, BOTH SIDES (SIDE 'B' SHOWN)

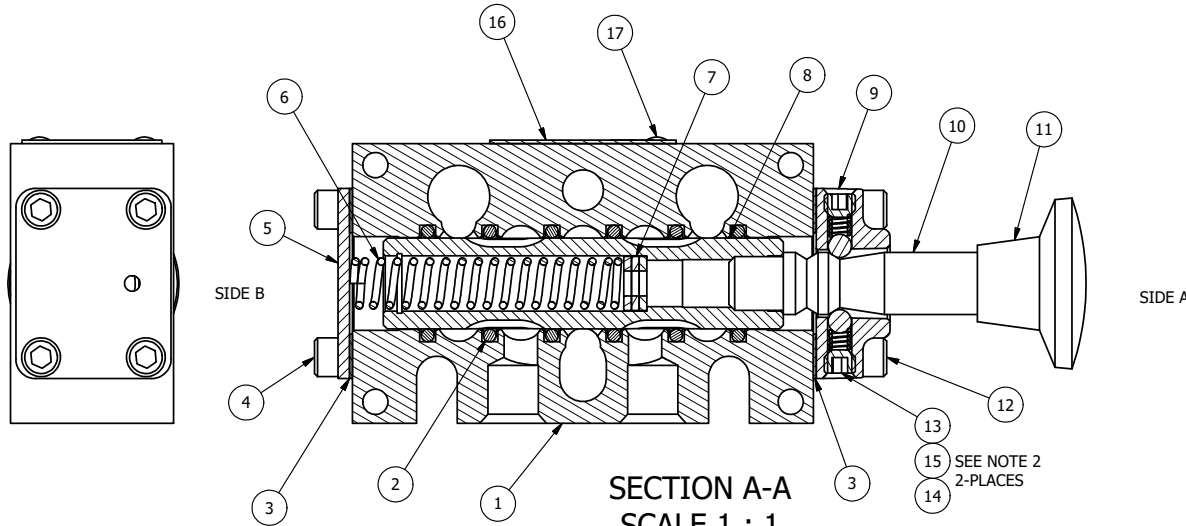

18	3	V-110	O-RING, BUNA-N, 70 DURO, AS-114, (REF 5/8 X 13/16 X 3/32), 1/4" SLEEVE, 1/2" SUB, STACK
17	2	V-212	SCREW, #2 X 3/16 DRIVE, TYPE U, OVAL HEAD, STAINLESS STEEL
16	1	AN-114	NAMEPLATE, BLANK, FOR VALVES WITH SPRINGS OR DETENTS
15	2	V-14	BALL, CHROME STEEL 3/16 DIA, GRADE 25, FOR DETENT
14	2	DS3	SPRING - DETENT, 1/4" & 3/8" VALVE
13	2	V-21	SCREW, 1/4-20 X 3/16, SOCKET SET, CUP POINT
12	4	V-38	SCREW, 10-24 X 3/4, SOCKET HEAD CAP
11	1	V-520	KNOB, BLACK (BRASS 5/16 - 18 INSERT), 5/16-18 X 7/16 THREAD, 1-3/8 DIA X 7/8 HEIGHT
10	1	PBS3-189	STUD - PALM, 189 ACTION, 1/4" & 3/8" VALVES
9	1	PEC3-3DD	END CAP, PALM, DOUBLE DETENT, 380 AL, 1/4" & 3/8" VALVE
8	1	SSH3G	SPOOL - 'G', 3 POS, FLOAT CTR, 1/4" & 3/8" VALVE
7	3	V-43	WASHER - SPRING CTR, 302/304 STAINLESS STEEL, 1/4" & 3/8" VALVES
6	1	CS3-1	SPRING - CENTERING, 1/4" & 3/8" VALVES
5	1	SEC3	END CAP, 304 STAINLESS STEEL, 1/4" & 3/8" VALVE
4	4	V-37	SCREW, 10-24 X 1/2, SOCKET HEAD CAP
3	2	ECG3	GASKET - END CAP, 1/4" & 3/8" VALVE
2	6	V-39	O-RING, VITON, STD BODY, 1/4" & 3/8" VALVES
1	1	B2-10E	FINISHED - SOLID BODY, UPPER PILOTS, 1/4" STACKING VALVE
FLG	QTY	PART NO	DESCRIPTION

NOTES:

- 1) ALWAYS GIVE VALVE MODEL AND PART NUMBER WHEN ORDERING PARTS.
- 2) LUBRICATE DETENT BALL, SPRING AND STUD.

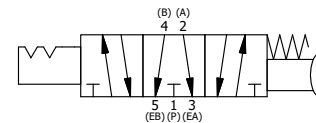

LIMITS ON DIMENSIONS UNLESS OTHERWISE SPECIFIED	2-PL DECIMAL ± .01 3-PL DECIMAL ± .005 FRACTIONAL ± 1/64 ANGULAR ± 1/2°	AAA PRODUCTS INTERNATIONAL 7114 Harry Hines Blvd Dallas, TX 75235	
DRAWN: RMckenna	DATE: 9/14/2016		CHECKED: KWaite
SCALE: 1:1	SHEET: 1 OF 1	RELEASED: HWomack	DATE: 9/14/2016
TITLE: 1/4" STACK, PALM, 3 POS, DETENT C, SPR CTR FROM A, FLOAT CTR SPL		PART NO.: BKW2G	REV.:

THE INFORMATION CONTAINED WITHIN THIS DOCUMENT IS PROPRIETARY TO AAA PRODUCTS AND MAY NOT BE DISCLOSED WITHOUT PRIOR WRITTEN CONSENT