

POSITION GASKET ON END OF VALVE TO SEAL PILOT HOLE IF PRESENT, BOTH SIDES (SIDE 'B' SHOWN)

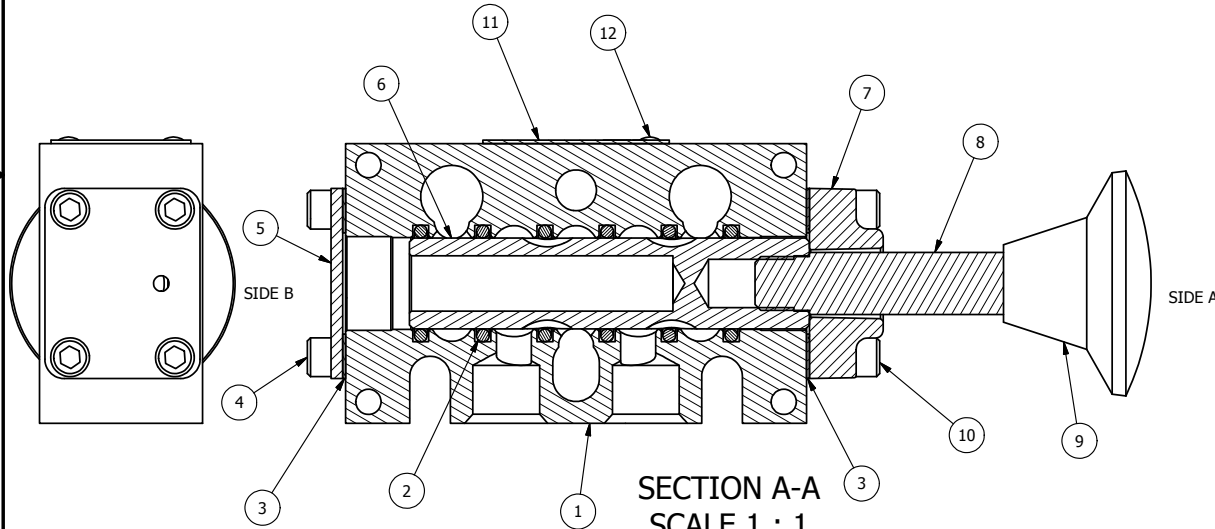

FLG	QTY	PART NO	DESCRIPTION
13	3	V-110	O-RING, 5/8 X 13/16 X 3/32 BUNA 70 D. FOR 1/4 SLEEVE VALVES & STACKING MANIFOLD
12	2	V-212	SCREW, #2 X 3/16 DRIVE, TYPE U, OVAL HEAD, 316 STAINLESS STEEL
11	1	AN-115	BLANK NAMEPLATE FOR HE,KE,KD,RR,D,CR,PP,SR,SS VALVES.
10	4	V-38	SCREW, 10-24 X 3/4 SHCS, FOR 3/8" CAST END CAP
9	1	V-543	KNOB, RED (BRASS 5/16-18 INSERT), PALM, 1 13/16 DIA, PUSH/PULL, 1/4" & 3/8" VALVES
8	1	PBS3	STUD - PALM, STANDARD, 1/4" & 3/8" VALVE
7	1	PEC3-2	END CAP, PALM, 380 AL, 1/4" & 3/8" VALVE
6	1	S3	SPOOL - STANDARD, 2 POS, CLSD CTR, 1/4" & 3/8" VALVE
5	1	SEC3	END CAP, STEEL, ZINC PLT, 1/4" & 3/8" VALVE
4	4	V-37	SCREW, 10-24 X 1/2 SHCS, FOR 1/8" STEEL END CAPS
3	2	ECG3	GASKET - END CAP, 1/4" & 3/8" VALVE
2	6	V-39	O-RING, STD BODY, VITON, 1/4" & 3/8" VALVES
1	1	B3-10E	FINISHED - SOLID BODY, UPPER PILOTS, 3/8" STACKING VALVE

NOTES:  
1) ALWAYS GIVE VALVE MODEL AND PART NUMBER WHEN ORDERING PARTS.

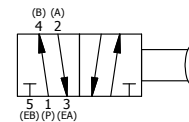

LIMITS ON DIMENSIONS UNLESS OTHERWISE SPECIFIED		2-PL DECIMAL ± .01 3-PL DECIMAL ± .005 FRACTIONAL ± 1/64 ANGULAR ± 1/2°		<b>AAA PRODUCTS INTERNATIONAL</b> 7114 Harry Hines Blvd Dallas, TX 75235	
DRAWN: RMckenna		DATE: 5/8/2015			
SCALE: 1:1		SHEET: 1 OF 1		CHECKED: KWaite DATE: 5/17/2015 RELEASED: HWomack DATE: 5/17/2015	
TITLE: <b>3/8" STACK, PALM, 2 POS, FRICTION POS, PALM RTRN, RED KNOB</b>				PART NO.: <b>BKE3J</b>	REV.:

THE INFORMATION CONTAINED WITHIN THIS DOCUMENT IS PROPRIETARY TO AAA PRODUCTS AND MAY NOT BE DISCLOSED WITHOUT PRIOR WRITTEN CONSENT

D:\Engineering\Inventory Files\Internal Drawings\Valves Assembly\Part\BKE3J.dwg