

POSITION GASKET ON END OF VALVE SO MOUNTING HOLES ALIGN, BOTH ENDS (SIDE 'A' SHOWN)

NOTES:
 1) ALWAYS GIVE VALVE MODEL AND PART NUMBER WHEN ORDERING PARTS.
 2) LUBRICATE DETENT BALL, SPRING AND STUD.

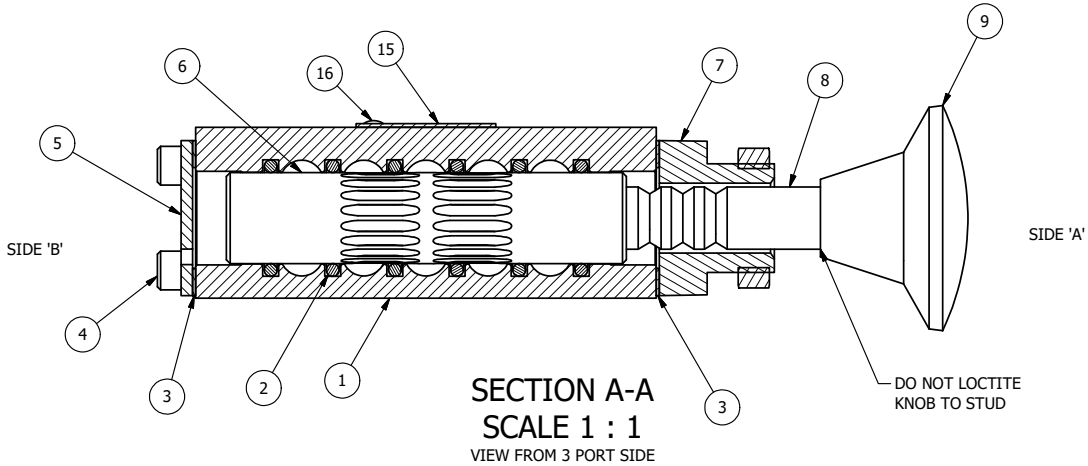

FLG	QTY	PART NO	DESCRIPTION
16	2	V-212	SCREW, #2 X 3/16 DRIVE, TYPE U, OVAL HEAD, STAINLESS STEEL
15	1	AN-114	NAMEPLATE, BLANK, FOR VALVES WITH SPRINGS OR DETENTS
14	1	V-14	BALL, CHROME STEEL 3/16 DIA, GRADE 25, FOR DETENT
13	1	DS3	SPRING - DETENT, 1/4" & 3/8" VALVE
12	1	V-21	SCREW, 1/4-20 X 3/16, SOCKET SET, CUP POINT
11	1	V-501	NUT - PANEL MOUNT, YELLOW BRASS, 1/4" & 3/8" VALVE
10	4	V-162	SCREW, 10-24 X 5/8, SOCKET HEAD CAP
9	1	V-543	KNOB, RED (BRASS 5/16-18 INSERT), PALM, 1 13/16 DIA, PUSH/PULL, 1/4" & 3/8" VALVES
8	1	PBS3-3	STUD - PALM, 3 POS. DETENT, 1/4" & 3/8" VALVE
7	1	PEC3-12	END CAP, PALM, PANEL MNT, DETENT, 303 STAINLESS STEEL, 1/4" & 3/8" VALVE
6	1	SSH3D	SPOOL - 'D', 3 POS, REGEN CTR, 1/4" & 3/8" VALVE
5	1	SEC3	END CAP, 304 STAINLESS STEEL, 1/4" & 3/8" VALVE
4	4	V-37	SCREW, 10-24 X 1/2, SOCKET HEAD CAP
3	2	ECG3	GASKET - END CAP, 1/4" & 3/8" VALVE
2	6	V-39	O-RING, VITON, STD BODY, 1/4" & 3/8" VALVES
1	1	B3-2E	BODY - SOLID, PLAIN, NO PILOTS, ANODIZED, 3/8" SIDE PORT VALVE

LIMITS ON DIMENSIONS
 UNLESS OTHERWISE SPECIFIED
 2-PL DECIMAL ± .01
 3-PL DECIMAL ± .005
 FRACTIONAL ± 1/64
 ANGULAR ± 1/2°

AAA PRODUCTS INTERNATIONAL
 7114 Harry Hines Blvd
 Dallas, TX 75235

DRAWN: RMckenna DATE: 5/15/2015 CHECKED: KWaite DATE: 5/17/2015
 SCALE: 1 : 1 SHEET: 1 OF 1 RELEASED: HWomack DATE: 5/17/2015

TITLE: 3/8" SIDE PORT, PALM, 3 POS, DETENT, PULL RTRN, REGEN CTR SPL, RED KNOB, PANEL MNT	PART NO.: KD3DJR	REV.:
--	---------------------	-------

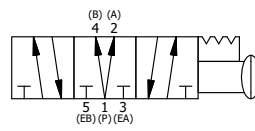

THE INFORMATION CONTAINED WITHIN THIS DOCUMENT IS PROPRIETARY TO AAA PRODUCTS AND MAY NOT BE DISCLOSED WITHOUT PRIOR WRITTEN CONSENT