

4 | 3 | 2 | 1

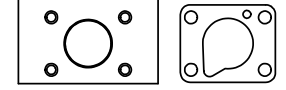

POSITION GASKET ON END OF VALVE SO MOUNTING HOLES ALIGN BOTH ENDS (SIDE 'B' SHOWN)

- NOTES:
 1) ALWAYS GIVE VALVE MODEL, AND PART NUMBER WHEN ORDERING PARTS.
 2) USE MASTER LOCK #7LJKAP176 (ORDERED SEPERATELY, #7LJ KEYPED ALIKE - KAP176).
 3) FOR MULTIPLE LOCKS, USE LOCKOUT HASP LO23 (ORDERED SEPERATELY).

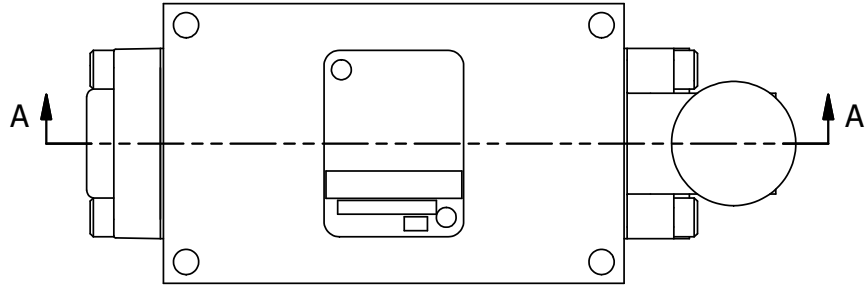
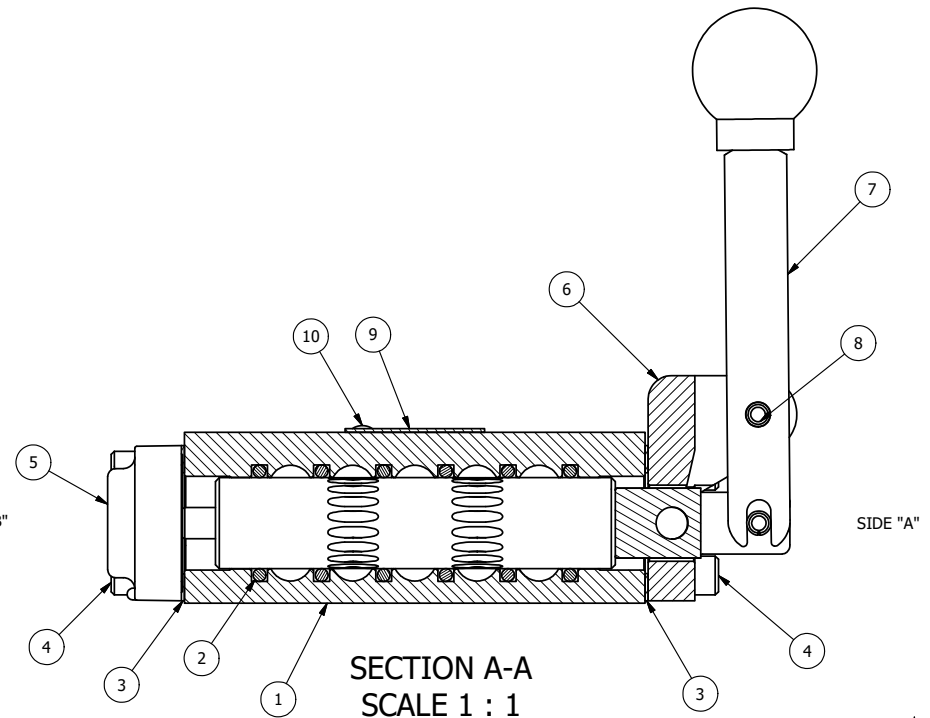

SECTION A-A
SCALE 1 : 1
 VIEW FROM 3 PORT SIDE

| FLG | QTY | PART NO | DESCRIPTION |
|-----|-----|-----------|--|
| 10 | 2 | V-212 | SCREW, #2 X 3/16 DRIVE, TYPE U, OVAL HEAD, STAINLESS STEEL |
| 9 | 1 | AN-114 | NAMEPLATE, BLANK, FOR VALVES WITH SPRINGS OR DETENTS |
| 8 | 1 | V-7 | PIN, ROLL 3/16 X 11/16, STEEL, FOR 1/4 THRU 1/2" HAND, FT & CAM V |
| 7 | 1 | HL3-24 | HAND LEVER WITH KNOB, 1/4" & 3/8" VALVE |
| 6 | 1 | HE3-1LO | END CAP, LEVER, LOCK OUT, 380 AL, 1/4" & 3/8" VALVE |
| 5 | 1 | AY-HY3LOB | ASSY - SPR CTR, CLSD CTR SPL, LEVER OR TREADLE, LOCKOUT 'B' 1/4 & 3/8 VALVES |
| 4 | 8 | V-38 | SCREW, 10-24 X 3/4, SOCKET HEAD CAP |
| 3 | 2 | ECG3 | GASKET - END CAP, 1/4" & 3/8" VALVE |
| 2 | 6 | V-39 | O-RING, VITON, STD BODY, 1/4" & 3/8" VALVES |
| 1 | 1 | B2-2E | BODY - SOLID, PLAIN, NO PILOTS, ANODIZED, 1/4" SIDE PORT VALVE |
| FLG | QTY | PART NO | DESCRIPTION |

| | | | | |
|--|----------------|--|--------------------|---|
| LIMITS ON DIMENSIONS UNLESS OTHERWISE SPECIFIED | | 2-PL DECIMAL ± .01 3-PL DECIMAL ± .005 FRACTIONAL ± 1/64 ANGULAR ± 1/2° | | <p>AAA PRODUCTS INTERNATIONAL 7114 Harry Hines Blvd Dallas, TX 75235</p> |
| DRAWN: RMckenna | DATE: 6/7/2015 | CHECKED: KWaite | DATE: 6/7/2015 | |
| SCALE: 1 : 1 | SHEET: 1 OF 1 | RELEASED: HWomack | DATE: 6/7/2015 | |
| TITLE: 1/4" SIDE PORT, LEVER, 3 POS, SPR CTR, CLSD CTR SPOOL, LOCKOUT B | | | PART NO.: HY2LO | REV.: |

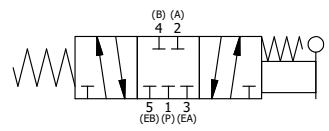

4 | 3 | 2 | 1

THE INFORMATION CONTAINED WITHIN THIS DOCUMENT IS PROPRIETARY TO AAA PRODUCTS AND MAY NOT BE DISCLOSED WITHOUT PRIOR WRITTEN CONSENT

P:\Engineering\Product\Valve Assembly\Level HY2LO\HY2LO.dwg