

NOTES:  
 1) ALWAYS GIVE VALVE MODEL, AND PART NUMBER WHEN ORDERING PARTS.  
 2) LUBRICATE DETENT BALL, SPRING AND CLEVIS.

16	1	ZNSPK-2	KIT - SUBPLATE MOUNTING, BRASS NAMUR, (2 EA V-618-SS SCREW, 2 EA V-565 O-RING)
15	1	V-548	O-RING, BUNA-N, 70 DURO, 6MM X 1MM, NAMUR PLUG
14	1	V-547	PLUG, 360 HALF HARD BRASS, NAMUR VALVE
13	1	V-14	BALL, CHROME STEEL 3/16 DIA, GRADE 25, FOR DETENT
12	1	DS3	SPRING - DETENT, 1/4" & 3/8" VALVE
11	1	V-21	SCREW, 1/4-20 X 3/16, SOCKET SET, CUP POINT
10	4	V-162-SS	SCREW, 10-24 X 5/8, SOCKET HEAD CAP, STAINLESS STEEL
9	1	V-542-SS	PIN, ROLL 3/16 X 1/2 NON-MAGNETIC STAINLESS STEEL FOR HE3-4 END CAP
8	1	V-521	KNOB, RED (BRASS 3/8-16 INSERT), 1" DIA BALL, 1/4" & 3/8" VALVE
7	1	HL3-SS	HAND LEVER, 303 STAINLESS STEEL, 1/4" & 3/8" VALVE
6	1	HE3-4D	ENDCAP - HAND, DETENT, 303 STAINLESS, 1/4" & 3/8" STACK VALVE
5	1	AY-HX3G-SA	ASSY - DETENT A, SPR CTR FRM C, FLOAT CTR, LEVER OR TREADLE, SS W/AL SPL, 1/4" & 3/8"
4	4	V-38-SS	SCREW, 10-24 X 3/4, SOCKET HEAD CAP, 18-8 SS
3	2	ECG3	GASKET - END CAP, 1/4" & 3/8" VALVE
2	6	V-39	O-RING, VITON, STD BODY, 1/4" & 3/8" VALVES
1	1	Z2-11	BODY - BRASS, UPPER PILOTS (BUTTON BLEEDER), 1/4" NAMUR
FLG	QTY	PART NO	DESCRIPTION

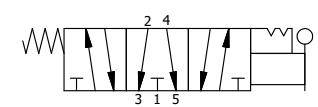
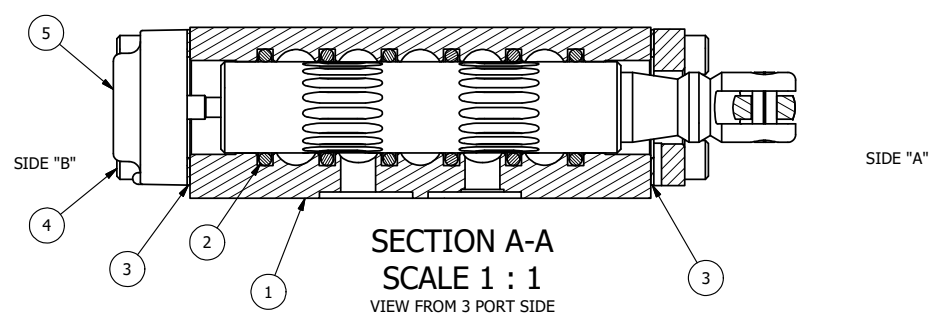

LIMITS ON DIMENSIONS UNLESS OTHERWISE SPECIFIED		2-PL DECIMAL ± .01 3-PL DECIMAL ± .005 FRACTIONAL ± 1/64 ANGULAR ± 1/2°	<b>AAA PRODUCTS INTERNATIONAL</b> 7114 Harry Hines Blvd Dallas, TX 75235
DRAWN: RMckenna	DATE: 2/9/2025	CHECKED: KWaite	
SCALE: 1:1	SHEET: 1 OF 1	RELEASED: HWomack	DATE: 2/9/2025
TITLE: 1/4" NAMUR, LEVER, 3 POS, DTNT A, FLOAT SPR CTR FRM C, BR&SS, RED KNB, 270D LVR		PART NO.: ZNHX2GJRT	REV.:

THE INFORMATION CONTAINED WITHIN THIS DOCUMENT IS PROPRIETARY TO AAA PRODUCTS AND MAY NOT BE DISCLOSED WITHOUT PRIOR WRITTEN CONSENT

D:\Engineering\Products\Valves\Assembly\lever\KWAITE\ZNHX2GJRT.dwg