

NOTES:  
 1) ALWAYS GIVE VALVE MODEL, AND PART NUMBER WHEN ORDERING PARTS.  
 2) LUBRICATE DETENT BALL, SPRING AND CLEVIS.

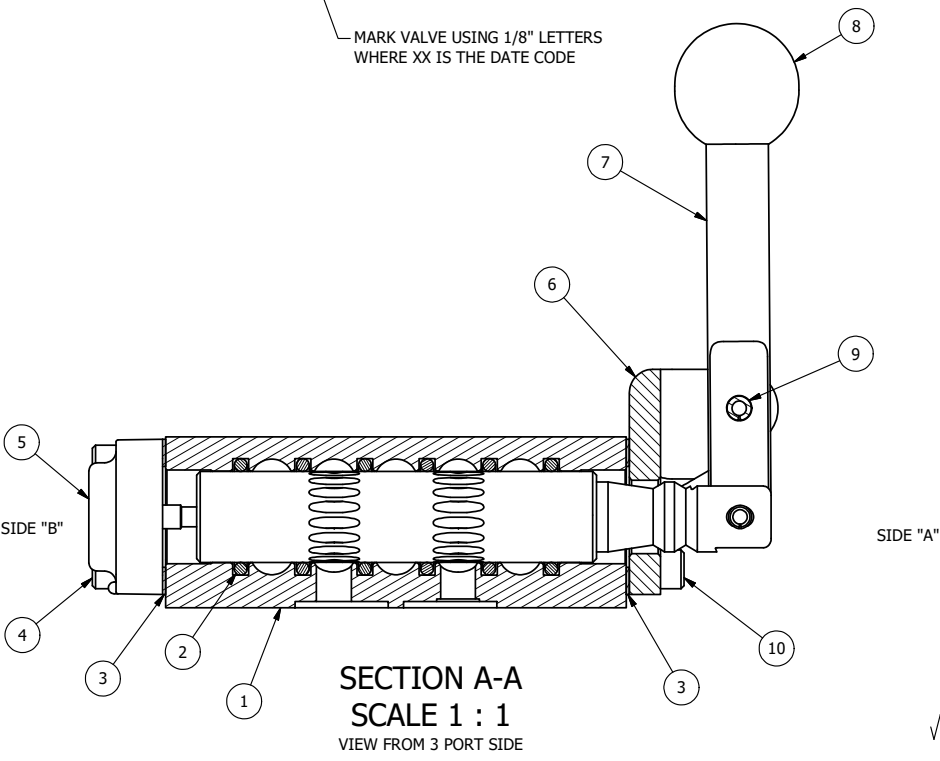

16	1	ZNSPK-2	KIT - SUBPLATE MOUNTING, BRASS NAMUR, (2 EA V-618-SS SCREW, 2 EA V-565 O-RING)
15	1	V-548	O-RING, BUNA-N, 70 DURO, 6MM X 1MM, NAMUR PLUG
14	1	V-547	PLUG, 360 HALF HARD BRASS, NAMUR VALVE
13	2	V-21-SS	SCREW, 1/4-20 X 3/16, SOCKET SET, CUP POINT, 18-8 SS
12	2	DS3-1	SPRING, DETENT, STAINLESS, 1/4" & 3/8" VALVE. LEE SPRING # LC 029B 0 S.
11	2	V-14-SS	BALL, 440C STAINLESS STEEL, 3/16 DIA. FOR DETENT
10	4	V-162-SS	SCREW, 10-24 X 5/8, SOCKET HEAD CAP, STAINLESS STEEL
9	1	V-508-SS	PIN, ROLL 3/16 X 5/8", 18-8 SS
8	1	V-580	KNOB, BLACK (BRASS 3/8-16 INSERT), 1" DIA BALL
7	1	HL3-SS	HAND LEVER, 303 STAINLESS STEEL, 1/4" & 3/8" VALVE
6	1	HE3-5DD	END CAP, LEVER, DOUBLE DETENT, 303 STAINLESS STEEL, 1/4" & 3/8" VALVE
5	1	AY-HX3-SA	ASSY - DETENT A, SPR CTR FRM C, CLSD CTR, LEVER OR TREADLE, SS W/AL SPL, 1/4" & 3/8"
4	4	V-38-SS	SCREW, 10-24 X 3/4, SOCKET HEAD CAP, 18-8 SS
3	2	ECG3	GASKET - END CAP, 1/4" & 3/8" VALVE
2	6	V-39	O-RING, VITON, STD BODY, 1/4" & 3/8" VALVES
1	1	Z2-11	BODY - BRASS, UPPER PILOTS (BUTTON BLEEDER), 1/4" NAMUR
FLG	QTY	PART NO	DESCRIPTION

LIMITS ON DIMENSIONS UNLESS OTHERWISE SPECIFIED		2-PL DECIMAL ± .01 3-PL DECIMAL ± .005 FRACTIONAL ± 1/64 ANGULAR ± 1/2°		<b>AAA PRODUCTS INTERNATIONAL</b> 7114 Harry Hines Blvd Dallas, TX 75235
DRAWN: RMckenna	DATE: 9/23/2016	CHECKED: KWaite	DATE: 9/23/2016	
SCALE: 1:1	SHEET: 1 OF 1	RELEASED: HWomack	DATE: 9/23/2016	
TITLE: 1/4" NAMUR, LEVER, 3 POS, DTNT A, CLSD SPR CTR FRM C, BR&SS			PART NO.: ZNHX2	REV.:

THE INFORMATION CONTAINED WITHIN THIS DOCUMENT IS PROPRIETARY TO AAA PRODUCTS AND MAY NOT BE DISCLOSED WITHOUT PRIOR WRITTEN CONSENT

D:\Engineering\Products\Valves\Assembly\lever\HX3\ZNHX2.dwg