

POSITION GASKET TO SEAL PILOT HOLE BOTH SIDES. (SIDE 'A' SHOWN)

NOTES:  
 1) ALWAYS GIVE VALVE MODEL, AND PART NUMBER WHEN ORDERING PARTS.  
 2) LUBRICATE DETENT BALL, SPRING AND CLEVIS.

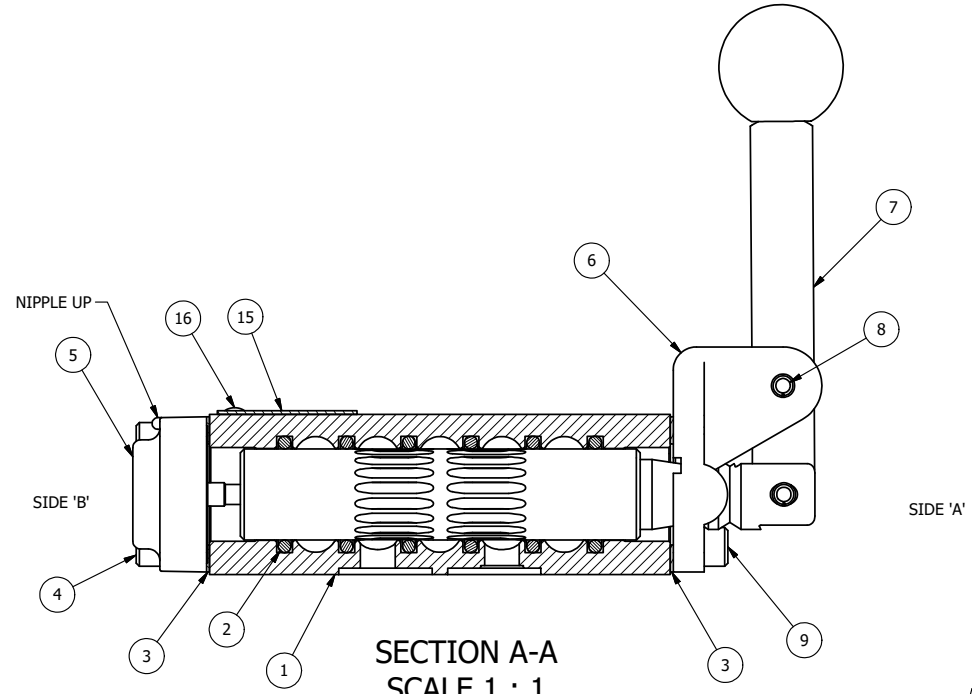

SECTION A-A  
 SCALE 1 : 1  
 VIEW FROM 3 PORT SIDE

|     |     |          |  |
|-----|-----|----------|--|
| 17  | 1   | NSPK-2   | KIT - SUBPLATE MOUNTING, NAMUR VALVES  |
| 16  | 2   | V-212    | SCREW, #2 X 3/16 DRIVE, TYPE U, OVAL HEAD, STAINLESS STEEL                           |
| 15  | 1   | AN-114   | NAMEPLATE, BLANK, FOR VALVES WITH SPRINGS OR DETENTS                                 |
| 14  | 1   | V-548    | O-RING, BUNA-N, 70 DURO, 6MM X 1MM, NAMUR PLUG                                       |
| 13  | 1   | V-547    | PLUG, 360 HALF HARD BRASS, NAMUR VALVE   |
| 12  | 1   | V-21     | SCREW, 1/4-20 X 3/16, SOCKET SET, CUP POINT  |
| 11  | 1   | DS3      | SPRING - DETENT, 1/4" & 3/8" VALVE   |
| 10  | 1   | V-14     | BALL, CHROME STEEL 3/16 DIA, GRADE 25, FOR DETENT                                    |
| 9   | 4   | V-162    | SCREW, 10-24 X 5/8, SOCKET HEAD CAP  |
| 8   | 1   | V-508    | PIN, ROLL 3/16 X 5/8 ZINC PLATED STEEL FOR 1/4 FOOT ENDCAP                           |
| 7   | 1   | HL3-521  | HAND LEVER WITH RED KNOB, 1/4" & 3/8" VALVE  |
| 6   | 1   | HE3-5D   | END CAP, LEVER, DETENT, 303 STAINLESS STEEL, 1/4" & 3/8" VALVE                       |
| 5   | 1   | AY-HX3D  | ASSY - DETENT A, SPR CTR FROM C, REGEN CTR SPL, LEVER OR TREADLE, 1/4" & 3/8" VALVES |
| 4   | 4   | V-38     | SCREW, 10-24 X 3/4, SOCKET HEAD CAP  |
| 3   | 2   | ECG3     | GASKET - END CAP, 1/4" & 3/8" VALVE  |
| 2   | 6   | V-39     | O-RING, VITON, STD BODY, 1/4" & 3/8" VALVES  |
| 1   | 1   | B2-11E-W | NAMUR INTERFACE, WITH 3/2 CONVERSION, 1/4" VALVE                                     |
| FLG | QTY | PART NO  | DESCRIPTION  |

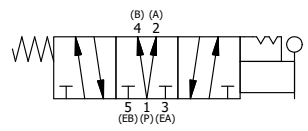

|  |                                 |                                 |  |
|--|---------------------------------|---------------------------------|--|
| LIMITS ON DIMENSIONS<br>UNLESS OTHERWISE SPECIFIED<br>2-PL DECIMAL ± .01<br>3-PL DECIMAL ± .005<br>FRACTIONAL ± 1/64<br>ANGULAR ± 1/2° |                                 |                                 | <b>AAA PRODUCTS INTERNATIONAL</b><br>7114 Harry Hines Blvd<br>Dallas, TX 75235 |
|  | DRAWN: RMckenna<br>SCALE: 1 : 1 | DATE: 2/9/2025<br>SHEET: 1 OF 1 | CHECKED: KWaite<br>RELEASED: HWomack   |
| TITLE:<br>1/4" NAMUR, LEVER, 3 POS,<br>DTNT A, REGEN SPR CTR FRM C,<br>HVY DTY, RED KNB  |                                 |                                 | PART NO.:<br>NHX2DHJ   |

THE INFORMATION CONTAINED WITHIN THIS DOCUMENT IS PROPRIETARY TO AAA PRODUCTS AND MAY NOT BE DISCLOSED WITHOUT PRIOR WRITTEN CONSENT

P:\Engineering\Products\Valves\Assembly\Levers\HX3\AAA\NHX2DHJ.dwg