

4 | 3 | 2 | 1

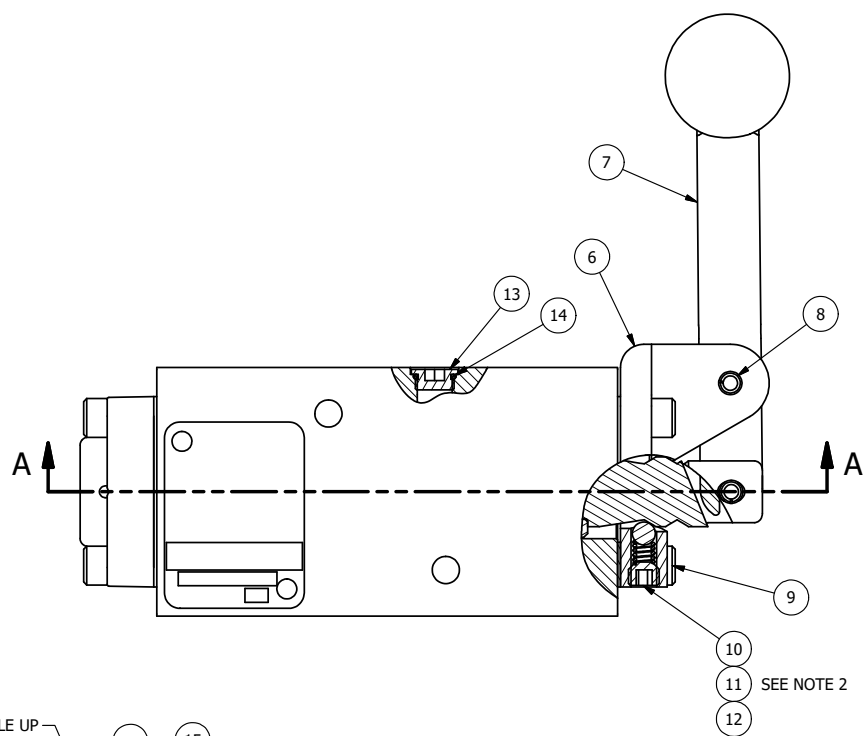

POSITION GASKET TO SEAL PILOT HOLE BOTH SIDES. (SIDE 'A' SHOWN)

NOTES:
 1) ALWAYS GIVE VALVE MODEL, AND PART NUMBER WHEN ORDERING PARTS.
 2) LUBRICATE DETENT BALL, SPRING AND CLEVIS.



SEE NOTE 2

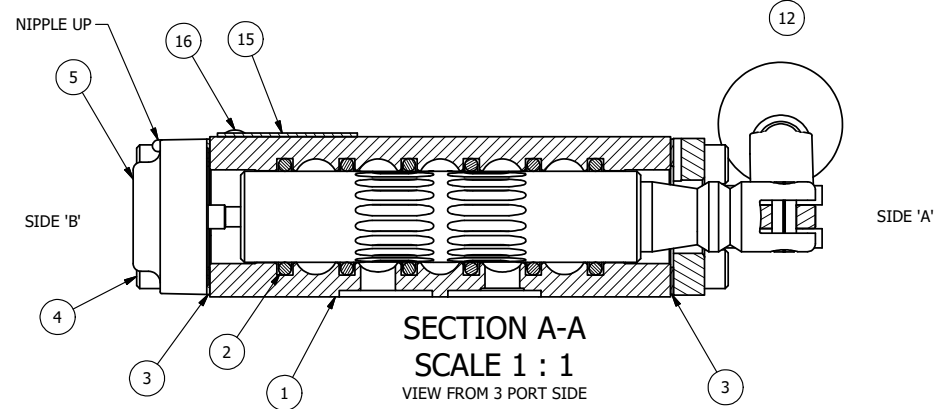

SECTION A-A
 SCALE 1 : 1
 VIEW FROM 3 PORT SIDE

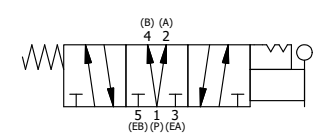

17	1	NSPK-2	KIT - SUBPLATE MOUNTING, NAMUR VALVES
16	2	V-212	SCREW, #2 X 3/16 DRIVE, TYPE U, OVAL HEAD, STAINLESS STEEL
15	1	AN-114	NAMEPLATE, BLANK, FOR VALVES WITH SPRINGS OR DETENTS
14	1	V-548	O-RING, BUNA-N, 70 DURO, 6MM X 1MM, NAMUR PLUG
13	1	V-547	PLUG, 360 HALF HARD BRASS, NAMUR VALVE
12	1	V-14	BALL, CHROME STEEL 3/16 DIA, GRADE 25, FOR DETENT
11	1	DS3	SPRING - DETENT, 1/4" & 3/8" VALVE
10	1	V-21	SCREW, 1/4-20 X 3/16, SOCKET SET, CUP POINT
9	4	V-162	SCREW, 10-24 X 5/8, SOCKET HEAD CAP
8	1	V-542	PIN, ROLL 3/16 X 1/2 ZINC PLATED STEEL FOR HE3-4 END CAP
7	1	HL3-521B20	HAND LEVER WITH RED KNOB, BENT 20 DEG SIDEWAYS, 1/4" & 3/8" VALVES
6	1	HE3-4D	ENDCAP - HAND, DETENT, 303 STAINLESS, 1/4" & 3/8" STACK VALVE
5	1	AY-HX3D	ASSY - DETENT A, SPR CTR FROM C, REGEN CTR SPL, LEVER OR TREADLE, 1/4" & 3/8" VALVES
4	4	V-38	SCREW, 10-24 X 3/4, SOCKET HEAD CAP
3	2	ECG3	GASKET - END CAP, 1/4" & 3/8" VALVE
2	6	V-39	O-RING, VITON, STD BODY, 1/4" & 3/8" VALVES
1	1	B2-11E-W	NAMUR INTERFACE, WITH 3/2 CONVERSION, 1/4" VALVE
FLG	QTY	PART NO	DESCRIPTION

LIMITS ON DIMENSIONS UNLESS OTHERWISE SPECIFIED		2-PL DECIMAL ± .01 3-PL DECIMAL ± .005 FRACTIONAL ± 1/64 ANGULAR ± 1/2°		<p>AAA PRODUCTS INTERNATIONAL 7114 Harry Hines Blvd Dallas, TX 75235</p>
DRAWN: RMckenna	DATE: 2/9/2025	CHECKED: KWaite	DATE: 2/9/2025	
SCALE: 1 : 1	SHEET: 1 OF 1	RELEASED: HWomack	DATE: 2/9/2025	
TITLE: 1/4" NAMUR, LEVER, 3 POS, DTNT A, REGEN SPR CTR FRM C, BNT LVR LFT, RED KNB, 90D LVR			PART NO.: NHX2DBLJR	REV.:

THE INFORMATION CONTAINED WITHIN THIS DOCUMENT IS PROPRIETARY TO AAA PRODUCTS AND MAY NOT BE DISCLOSED WITHOUT PRIOR WRITTEN CONSENT

B
A

B
A

4 | 3 | 2 | 1