

POSITION GASKET ON END OF VALVE SO GASKET COVERS PILOT HOLE BOTH SIDES (SIDE 'A' SHOWN)

NOTES:
 1) ALWAYS GIVE VALVE MODEL AND PART NUMBER WHEN ORDERING PARTS.
 2) LUBRICATE DETENT BALL, SPRING AND CLEVIS.

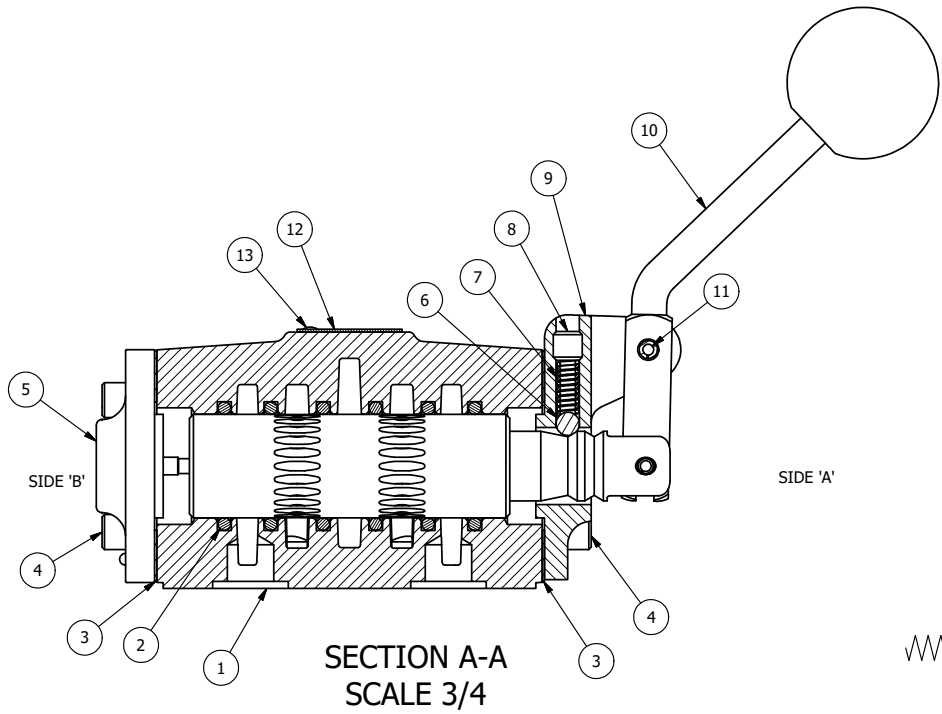

FLG	QTY	PART NO	DESCRIPTION
14	1	SPK-4	KIT - SUBPLATE MOUNT, 1/2" SUBPLATE VALVES
13	2	V-212	SCREW, #2 X 3/16 DRIVE, TYPE U, OVAL HEAD, STAINLESS STEEL
12	1	AN-114	NAMEPLATE, BLANK, FOR VALVES WITH SPRINGS OR DETENTS
11	1	V-10	PIN, ROLL 3/16 X 7/8, STEEL
10	1	HL4-9C	HAND LEVER ASSEMBLY, CURVED LEVER, 1/2" VALVE
9	1	FE4-3	END CAP - HAND & FOOT, DETENT, 380 AL, 1/2" VALVE
8	1	V-8	SCREW, 5/16-18 X 5/16, SOCKET SET, CUP POINT
7	1	DS48	SPRING - DETENT, 1/2", 3/4" & 1" VALVE
6	1	V-4	BALL, CHROME STEEL 1/4 DIA. FOR DETENT
5	1	AY-HX4	ASSY - DETENT A, SPR CTR FROM C, CLSD CTR SPL, LEVER OR TREADLE, 1/2" VALVE
4	8	V-46	SCREW, 1/4-20 X 3/4, SOCKET HEAD CAP
3	2	ECG48	GASKET - END CAP, 1/2", 3/4" & 1" VALVE
2	6	V-6	O-RING, BUNA-N, 70 DURO, AS-216, (REF 1-1/8 X 1-3/8 X 1/8), 1/2" VALVES, 1" SUBPLATE
1	1	BP4-1	BODY, 1/2" SUBPLATE, UPPER PILOTS, ANODIZED

LIMITS ON DIMENSIONS UNLESS OTHERWISE SPECIFIED		2-PL DECIMAL ± .01 3-PL DECIMAL ± .005 FRACTIONAL ± 1/64 ANGULAR ± 1/2°		AAA PRODUCTS INTERNATIONAL 7114 Harry Hines Blvd Dallas, TX 75235
DRAWN: RMckenna	DATE: 3/1/2016	CHECKED: KWaite	DATE: 3/1/2016	
SCALE: 3/4	SHEET: 1 OF 1	RELEASED: HWomack	DATE: 3/1/2016	
TITLE: 1/2" SUBPLATE, LEVER, 3 POS, DTNT A, CLSD SPR CTR FRM C, CRVD LVR			PART NO.: HX4PC	REV.:

THE INFORMATION CONTAINED WITHIN THIS DOCUMENT IS PROPRIETARY TO AAA PRODUCTS AND MAY NOT BE DISCLOSED WITHOUT PRIOR WRITTEN CONSENT

D:\Engineering\Products\Valves\Assembly\lever\HX4\GTRKPC.dwg