

POSITION GASKET ON END OF VALVE SO
MOUNTING HOLES ALIGN
BOTH ENDS (SIDE 'A' SHOWN)

NOTES:
1) ALWAYS GIVE VALVE MODEL, AND PART NUMBER WHEN ORDERING PARTS.
2) LUBRICATE DETENT BALL, SPRING AND CLEVIS.

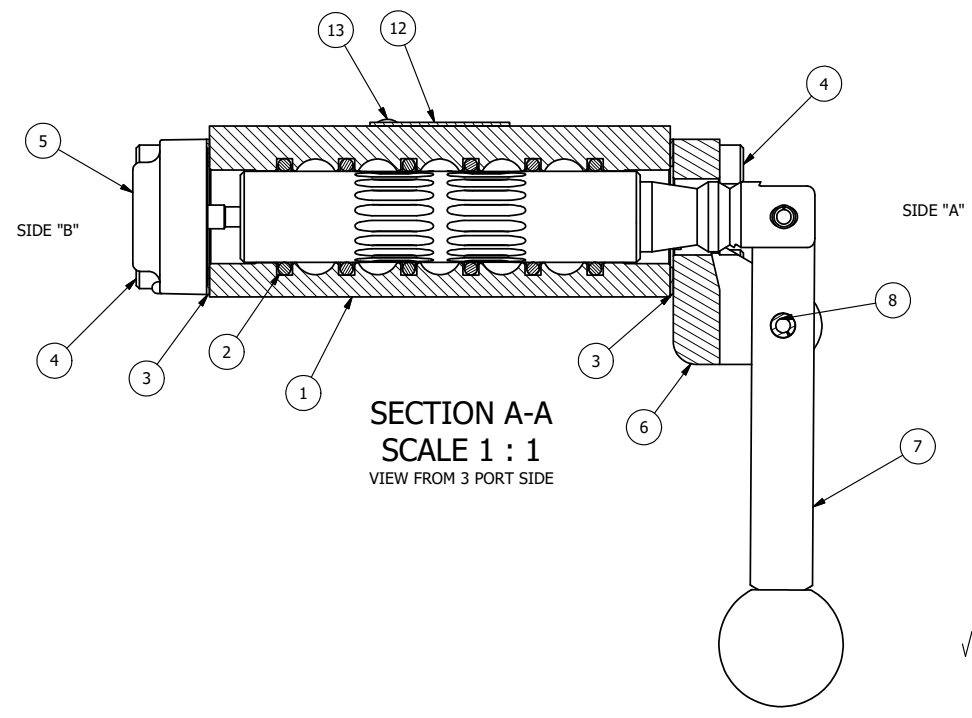

FLG	QTY	PART NO	DESCRIPTION
13	2	V-212	SCREW, #2 X 3/16 DRIVE, TYPE U, OVAL HEAD, STAINLESS STEEL
12	1	AN-114	NAMEPLATE, BLANK, FOR VALVES WITH SPRINGS OR DETENTS
11	2	V-14	BALL, CHROME STEEL 3/16 DIA, GRADE 25, FOR DETENT
10	2	DS3	SPRING - DETENT, 1/4" & 3/8" VALVE
9	2	V-21	SCREW, 1/4-20 X 3/16, SOCKET SET, CUP POINT
8	1	V-7	PIN, ROLL 3/16 X 11/16, STEEL, FOR 1/4 THRU 1/2" HAND, FT & CAM V
7	1	HL3-521	HAND LEVER WITH RED KNOB, 1/4" & 3/8" VALVE
6	1	HE3-3DD	END CAP, LEVER, DOUBLE DETENT, 380 AL, 1/4" & 3/8" VALVE
5	1	AY-HX3D	ASSY - DETENT A, SPR CTR FROM C, REGEN CTR SPL, LEVER OR TREADLE, 1/4" & 3/8" VALVES
4	8	V-38	SCREW, 10-24 X 3/4, SOCKET HEAD CAP
3	2	ECG3	GASKET - END CAP, 1/4" & 3/8" VALVE
2	6	V-39	O-RING, VITON, STD BODY, 1/4" & 3/8" VALVES
1	1	B3-2E	BODY - SOLID, PLAIN, NO PILOTS, ANODIZED, 3/8" SIDE PORT VALVE

LIMITS ON DIMENSIONS UNLESS OTHERWISE SPECIFIED		2-PL DECIMAL ± .01 3-PL DECIMAL ± .005 FRACTIONAL ± 1/64 ANGULAR ± 1/2°		AAA PRODUCTS INTERNATIONAL 7114 Harry Hines Blvd Dallas, TX 75235
DRAWN: RMckenna	DATE: 2/9/2025	CHECKED: KWaite	DATE: 2/9/2025	
SCALE: 1 : 1	SHEET: 1 OF 1	RELEASED: HWomack	DATE: 2/9/2025	
TITLE: 3/8" SIDE PORT, LEVER, 3 POS, DTNT A, REGEN SPR CTR FRM C, RED KNB, 180D LVR			PART NO.: HX3DJT	REV.:

THE INFORMATION CONTAINED WITHIN THIS DOCUMENT IS PROPRIETARY TO AAA PRODUCTS AND MAY NOT BE DISCLOSED WITHOUT PRIOR WRITTEN CONSENT

P:\Engineering\Products\Valves\Assembly\Lever\HX3DJT.dwg