

POSITION GASKET ON END OF VALVE TO SEAL PILOT HOLE IF PRESENT, BOTH SIDES (SIDE 'B' SHOWN)

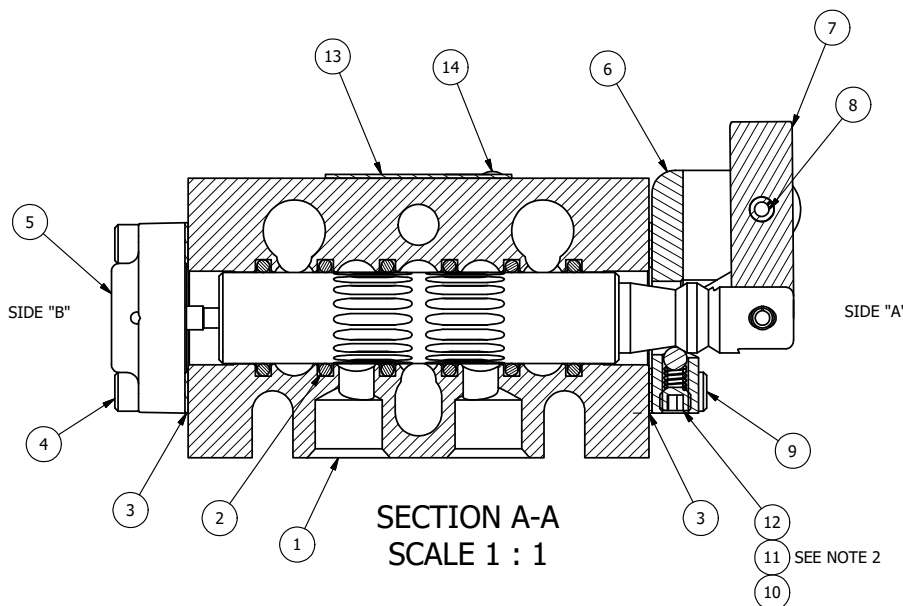

NOTES:
 1) ALWAYS GIVE VALVE MODEL AND PART NUMBER WHEN ORDERING PARTS.
 2) LUBRICATE DETENT BALL, SPRING AND CLEVIS.

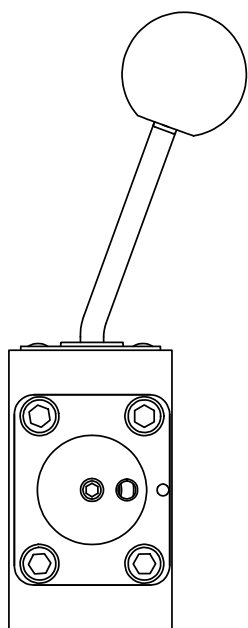
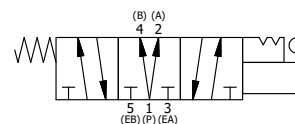

| FLG | QTY | PART NO | DESCRIPTION |
|-----|-----|------------|---|
| 15 | 3 | V-110 | O-RING, BUNA-N, 70 DURO, AS-114, (REF 5/8 X 13/16 X 3/32), 1/4" SLEEVE, 1/2" SUB, STACK |
| 14 | 2 | V-212 | SCREW, #2 X 3/16 DRIVE, TYPE U, OVAL HEAD, STAINLESS STEEL |
| 13 | 1 | AN-114 | NAMEPLATE, BLANK, FOR VALVES WITH SPRINGS OR DETENTS |
| 12 | 1 | V-21 | SCREW, 1/4-20 X 3/16, SOCKET SET, CUP POINT |
| 11 | 1 | DS3 | SPRING - DETENT, 1/4" & 3/8" VALVE |
| 10 | 1 | V-14 | BALL, CHROME STEEL 3/16 DIA, GRADE 25, FOR DETENT |
| 9 | 4 | V-162 | SCREW, 10-24 X 5/8, SOCKET HEAD CAP |
| 8 | 1 | V-542 | PIN, ROLL 3/16 X 1/2 ZINC PLATED STEEL FOR HE3-4 END CAP |
| 7 | 1 | HL3-521B20 | HAND LEVER WITH RED KNOB, BENT 20 DEG SIDEWAYS, 1/4" & 3/8" VALVES |
| 6 | 1 | HE3-4D | ENDCAP - HAND, DETENT, 303 STAINLESS, 1/4" & 3/8" STACK VALVE |
| 5 | 1 | AY-HX3D | ASSY - DETENT A, SPR CTR FROM C, REGEN CTR SPL, LEVER OR TREADLE, 1/4" & 3/8" VALVES |
| 4 | 4 | V-38 | SCREW, 10-24 X 3/4, SOCKET HEAD CAP |
| 3 | 2 | ECG3 | GASKET - END CAP, 1/4" & 3/8" VALVE |
| 2 | 6 | V-39 | O-RING, VITON, STD BODY, 1/4" & 3/8" VALVES |
| 1 | 1 | B3-10E | FINISHED - SOLID BODY, UPPER PILOTS, 3/8" STACKING VALVE |

| | | | | |
|--|----------------|--|------------------------------|--|
| LIMITS ON DIMENSIONS UNLESS OTHERWISE SPECIFIED | | 2-PL DECIMAL ± .01 3-PL DECIMAL ± .005 FRACTIONAL ± 1/64 ANGULAR ± 1/2° | | AAA PRODUCTS INTERNATIONAL 7114 Harry Hines Blvd Dallas, TX 75235 |
| DRAWN: RMckenna | DATE: 2/8/2025 | CHECKED: KWaite | DATE: 2/8/2025 | |
| SCALE: 1:1 | SHEET: 1 OF 1 | RELEASED: HWomack | DATE: 2/8/2025 | |
| TITLE: 3/8" STACK, LEVER, 3 POS, DTNT A, REGEN SPR CTR FRM C, BNT LVR LFT, RED KNB | | | PART NO.: BHX3DBLJ | REV.: |

THE INFORMATION CONTAINED WITHIN THIS DOCUMENT IS PROPRIETARY TO AAA PRODUCTS AND MAY NOT BE DISCLOSED WITHOUT PRIOR WRITTEN CONSENT

D:\Engineering\product\valves\assembly\lever\HX3D\BHX3DBLJ.dwg