

POSITION GASKET ON END OF VALVE TO SEAL PILOT HOLE IF PRESENT, BOTH SIDES (SIDE 'B' SHOWN)

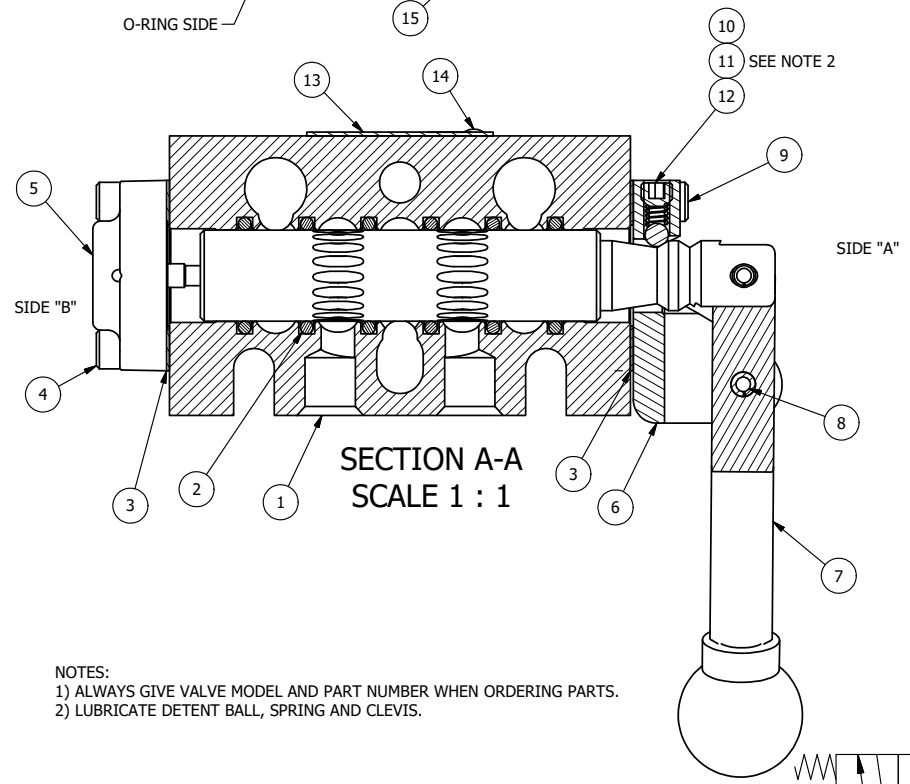

SECTION A-A  
SCALE 1 : 1

- NOTES:  
 1) ALWAYS GIVE VALVE MODEL AND PART NUMBER WHEN ORDERING PARTS.  
 2) LUBRICATE DETENT BALL, SPRING AND CLEVIS.

15	3	V-110	O-RING, BUNA-N, 70 DURO, AS-114, (REF 5/8 X 13/16 X 3/32), 1/4" SLEEVE, 1/2" SUB, STACK
14	2	V-212	SCREW, #2 X 3/16 DRIVE, TYPE U, OVAL HEAD, STAINLESS STEEL
13	1	AN-114	NAMEPLATE, BLANK, FOR VALVES WITH SPRINGS OR DETENTS
12	1	V-21	SCREW, 1/4-20 X 3/16, SOCKET SET, CUP POINT
11	1	DS3	SPRING - DETENT, 1/4" & 3/8" VALVE
10	1	V-14	BALL, CHROME STEEL 3/16 DIA, GRADE 25, FOR DETENT
9	4	V-162	SCREW, 10-24 X 5/8, SOCKET HEAD CAP
8	1	V-542	PIN, ROLL 3/16 X 1/2 ZINC PLATED STEEL FOR HE3-4 END CAP
7	1	HL3-24B20	HAND LEVER WITH KNOB, BENT 20 DEG SIDEWAYS, 1/4" & 3/8" VALVES
6	1	HE3-4D	ENDCAP - HAND, DETENT, 303 STAINLESS, 1/4" & 3/8" STACK VALVE
5	1	AY-HX3	ASSY - DETENT A, SPR CTR FROM C, CLSD CTR SPL, LEVER OR TREADLE, 1/4" & 3/8" VALVES
4	4	V-38	SCREW, 10-24 X 3/4, SOCKET HEAD CAP
3	2	ECG3	GASKET - END CAP, 1/4" & 3/8" VALVE
2	6	V-39	O-RING, VITON, STD BODY, 1/4" & 3/8" VALVES
1	1	B2-10E	FINISHED - SOLID BODY, UPPER PILOTS, 1/4" STACKING VALVE
FLG	QTY	PART NO	DESCRIPTION

LIMITS ON DIMENSIONS  
 UNLESS OTHERWISE SPECIFIED  
 2-PL DECIMAL ± .01  
 3-PL DECIMAL ± .005  
 FRACTIONAL ± 1/64  
 ANGULAR ± 1/2°

**AAA PRODUCTS INTERNATIONAL**  
 7114 Harry Hines Blvd  
 Dallas, TX 75235

DRAWN: RMckenna DATE: 5/8/2022 CHECKED: KWaite DATE: 5/8/2022  
 SCALE: 1 : 1 SHEET: 1 OF 1 RELEASED: HWomack DATE: 5/8/2022

TITLE: 1/4" STACK, LEVER, 3 POS, DTNT A, CLSD SPR CTR FRM C, BNT LVR LFT, 180D LVR	PART NO.: BHX2BLT	REV.:
---	----------------------	-------

THE INFORMATION CONTAINED WITHIN THIS DOCUMENT IS PROPRIETARY TO AAA PRODUCTS AND MAY NOT BE DISCLOSED WITHOUT PRIOR WRITTEN CONSENT

D:\Engineering\product\valves\assembly\lever\HX3\BHX2BLT.dwg