

4 | 3 | 2 | 1

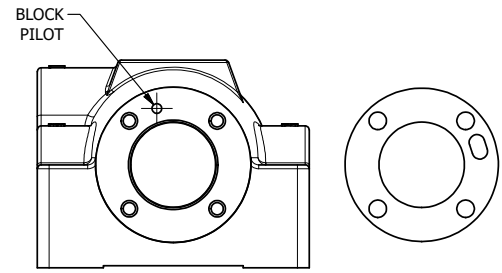

POSITION GASKET ON END OF VALVE SO GASKET COVERS PILOT HOLE BOTH SIDES (SIDE 'A' SHOWN)

NOTES:  
 1) ALWAYS GIVE VALVE MODEL AND PART NUMBER WHEN ORDERING PARTS.  
 2) LUBRICATE SPRINGS, AND DETENT BALL.

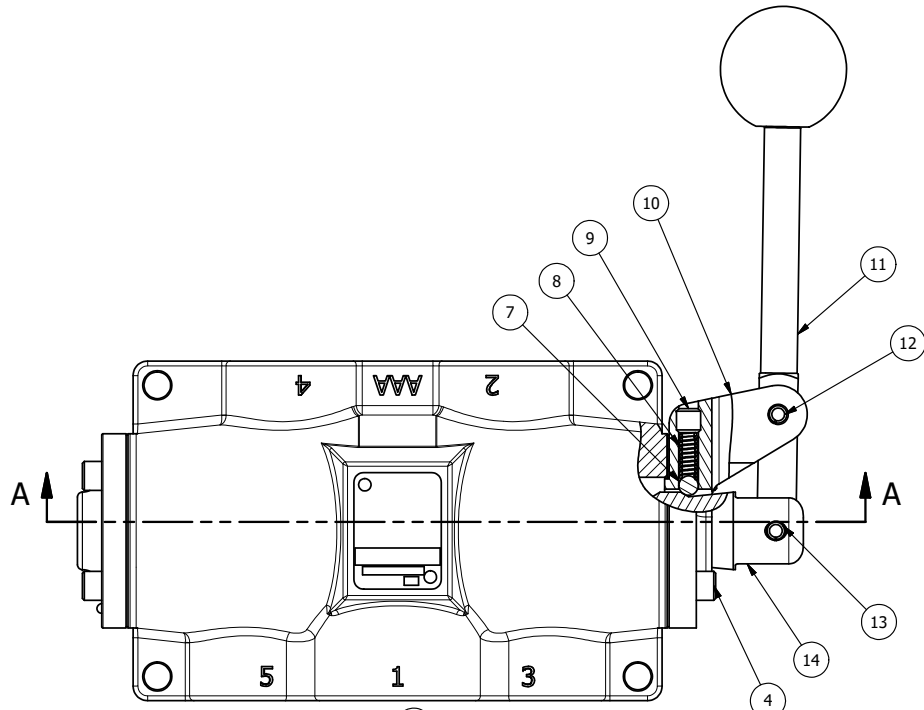
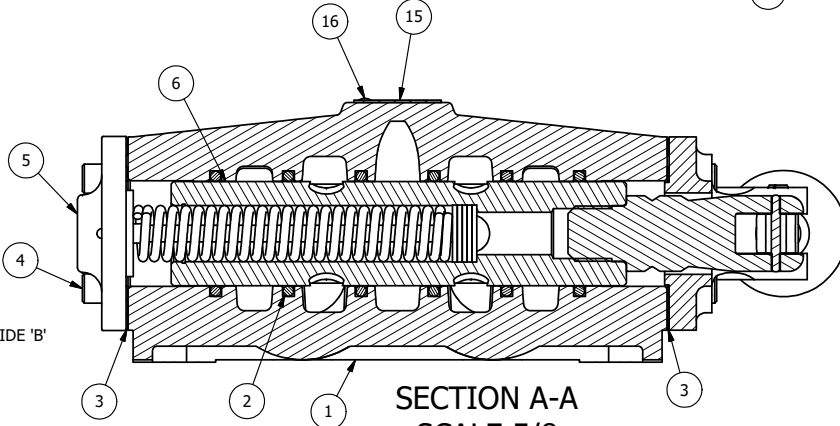

SECTION A-A  
 SCALE 5/8  
 VIEW FROM 3 PORT SIDE

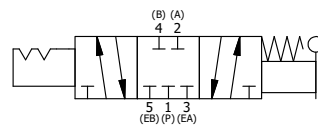

16	2	V-212	SCREW, #2 X 3/16 DRIVE, TYPE U, OVAL HEAD, STAINLESS STEEL
15	1	AN-114	NAMEPLATE, BLANK, FOR VALVES WITH SPRINGS OR DETENTS
14	1	SC8-332VY	CLEVIS - 332VY, 189VY ACTION, 3/4" & 1" VALVE
13	1	V-51-SS	PIN, ROLL 1/4 X 1 FOR 3/4" & 1" HAND FOOT & CAM VALVES, STAINLESS STEEL
12	1	V-70	PIN, ROLL 1/4 X 1 1/8 FOR 3/4" & 1" HAND AND FOOT VALVES
11	1	HL8-9	HAND LEVER ASSEMBLY, 3/4" & 1" VALVE
10	1	FE8-3	END CAP, HAND & FOOT, DETENT, STEEL, NICKEL PLT, 3/4" & 1" VALVES
9	1	V-8	SCREW, 5/16-18 X 5/16, SOCKET SET, CUP POINT
8	1	DS48	SPRING - DETENT, 1/2", 3/4" & 1" VALVE
7	1	V-4	BALL, CHROME STEEL 1/4 DIA. FOR DETENT
6	1	SSH8	SPOOL - STANDARD, 3 POS, CLSD CTR, 3/4" & 1" VALVE
5	1	AY-HW8	ASSY - SPR CTR FROM A, 189VY ACTION, 3/4" & 1" VALVE
4	8	V-46	SCREW, 1/4-20 X 3/4, SOCKET HEAD CAP
3	2	ECG48	GASKET - END CAP, 1/2", 3/4" & 1" VALVE
2	6	V-30	O-RING, BUNA-N, 70 DURO, AS-220, (REF 1-3/8 X 1-5/8 X 1/8), 3/4" & 1" VALVES
1	1	B8-1	BODY, 1" SIDE PORT, UPPER PILOTS, ANODIZED
FLG	QTY	PART NO	DESCRIPTION

LIMITS ON DIMENSIONS UNLESS OTHERWISE SPECIFIED		2-PL DECIMAL ± .01 3-PL DECIMAL ± .005 FRACTIONAL ± 1/64 ANGULAR ± 1/2°		<p><b>AAA PRODUCTS INTERNATIONAL</b>                  7114 Harry Hines Blvd                  Dallas, TX 75235</p>
DRAWN: RMckenna	DATE: 2/23/2016	CHECKED: KWaite	DATE: 2/23/2016	
SCALE: 3/4	SHEET: 1 OF 1	RELEASED: HWomack	DATE: 2/23/2016	
TITLE: 1" SIDE PORT, LEVER, 3 POS, DETENT C, SPR CTR FROM A, CLSD CTR SPL, 90D LEVER			PART NO.: HW8R	REV.:

THE INFORMATION CONTAINED WITHIN THIS DOCUMENT IS PROPRIETARY TO AAA PRODUCTS AND MAY NOT BE DISCLOSED WITHOUT PRIOR WRITTEN CONSENT

4 | 3 | 2 | 1

P:\Engineering\product\Valve Assembly\Level HW8R\HW8R.dwg