

POSITION GASKET ON END OF VALVE SO GASKET COVERS PILOT HOLE BOTH SIDES (SIDE 'A' SHOWN)

NOTES:
 1) ALWAYS GIVE VALVE MODEL AND PART NUMBER WHEN ORDERING PARTS.
 2) LUBRICATE SPRINGS, AND DETENT BALL.

| | | | |
|-----|-----|-----------|--|
| 16 | 2 | V-212 | SCREW, #2 X 3/16 DRIVE, TYPE U, OVAL HEAD, STAINLESS STEEL |
| 15 | 1 | AN-114 | NAMEPLATE, BLANK, FOR VALVES WITH SPRINGS OR DETENTS |
| 14 | 1 | SC8-332VY | CLEVIS - 332VY, 189VY ACTION, 3/4" & 1" VALVE |
| 13 | 1 | V-51-SS | PIN, ROLL 1/4 X 1 FOR 3/4" & 1" HAND FOOT & CAM VALVES, STAINLESS STEEL |
| 12 | 1 | V-70 | PIN, ROLL 1/4 X 1 1/8 FOR 3/4" & 1" HAND AND FOOT VALVES |
| 11 | 1 | HL8-9 | HAND LEVER ASSEMBLY, 3/4" & 1" VALVE |
| 10 | 1 | FE8-3 | END CAP, HAND & FOOT, DETENT, STEEL, NICKEL PLT, 3/4" & 1" VALVES |
| 9 | 1 | V-8 | SCREW, 5/16-18 X 5/16, SOCKET SET, CUP POINT |
| 8 | 1 | DS48 | SPRING - DETENT, 1/2", 3/4" & 1" VALVE |
| 7 | 1 | V-4 | BALL, CHROME STEEL 1/4 DIA. FOR DETENT |
| 6 | 1 | SSH8D | SPOOL - 'D', 3 POS, REGEN CTR, 3/4" & 1" VALVE |
| 5 | 1 | AY-HW8 | ASSY - SPR CTR FROM A, 189VY ACTION, 3/4" & 1" VALVE |
| 4 | 8 | V-46 | SCREW, 1/4-20 X 3/4, SOCKET HEAD CAP |
| 3 | 2 | ECG48 | GASKET - END CAP, 1/2", 3/4" & 1" VALVE |
| 2 | 6 | V-30 | O-RING, BUNA-N, 70 DURO, AS-220, (REF 1-3/8 X 1-5/8 X 1/8), 3/4" & 1" VALVES |
| 1 | 1 | B8-1 | BODY, 1" SIDE PORT, UPPER PILOTS, ANODIZED |
| FLG | QTY | PART NO | DESCRIPTION |

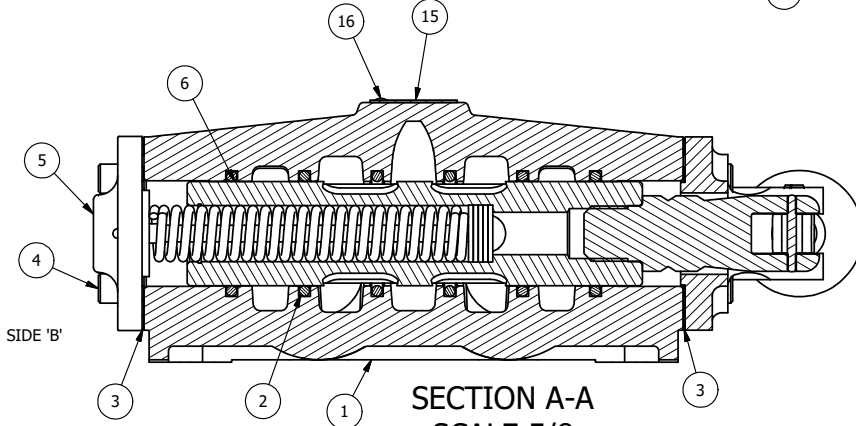

SECTION A-A
 SCALE 5/8
 VIEW FROM 3 PORT SIDE

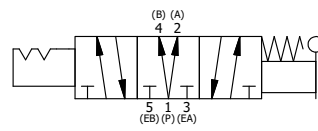

| | | | | |
|---|-----------------|--|-----------------|--|
| LIMITS ON DIMENSIONS UNLESS OTHERWISE SPECIFIED | | 2-PL DECIMAL ± .01 3-PL DECIMAL ± .005 FRACTIONAL ± 1/64 ANGULAR ± 1/2° | | AAA PRODUCTS INTERNATIONAL 7114 Harry Hines Blvd Dallas, TX 75235 |
| DRAWN: RMckenna | DATE: 2/27/2016 | CHECKED: KWaite | DATE: 2/27/2016 | |
| SCALE: 3/4 | SHEET: 1 OF 1 | RELEASED: HWomack | DATE: 2/27/2016 | |
| TITLE: 1" SIDE PORT, LEVER, 3 POS, DETENT C, SPR CTR FROM A, REGEN CTR SPL, 90D LEVER | | | PART NO.: HW8DR | REV.: |

THE INFORMATION CONTAINED WITHIN THIS DOCUMENT IS PROPRIETARY TO AAA PRODUCTS AND MAY NOT BE DISCLOSED WITHOUT PRIOR WRITTEN CONSENT

P:\Engineering\Product\Valve Assembly\Level HW8\GHW8DR.dwg