

POSITION GASKET ON END OF VALVE SO GASKET COVERS PILOT HOLE BOTH SIDES (SIDE 'A' SHOWN)

NOTES:
 1) ALWAYS GIVE VALVE MODEL AND PART NUMBER WHEN ORDERING PARTS.
 2) LUBRICATE SPRINGS, AND DETENT BALL.

16	2	V-212	SCREW, #2 X 3/16 DRIVE, TYPE U, OVAL HEAD, STAINLESS STEEL
15	1	AN-114	NAMEPLATE, BLANK, FOR VALVES WITH SPRINGS OR DETENTS
14	1	SC8-332VY	CLEVIS - 332VY, 189VY ACTION, 3/4" & 1" VALVE
13	1	V-51-SS	PIN, ROLL 1/4 X 1 FOR 3/4 & 1" HAND FOOT & CAM VALVES, STAINLESS STEEL
12	1	V-70	PIN, ROLL 1/4 X 1 1/8 FOR 3/4 & 1" HAND AND FOOT VALVES
11	1	HL8-9	HAND LEVER ASSEMBLY, 3/4" & 1" VALVE
10	1	FE8-3	END CAP, HAND & FOOT, DETENT, STEEL, NICKEL PLT, 3/4" & 1" VALVES
9	1	V-8	SCREW, 5/16-18 X 5/16, SOCKET SET, CUP POINT
8	1	DS48	SPRING - DETENT, 1/2", 3/4" & 1" VALVE
7	1	V-4	BALL, CHROME STEEL 1/4 DIA. FOR DETENT
6	1	SSH8D	SPOOL - 'D', 3 POS, REGEN CTR, 3/4" & 1" VALVE
5	1	AY-HW8	ASSY - SPR CTR FROM A, 189VY ACTION, 3/4" & 1" VALVE
4	8	V-46	SCREW, 1/4-20 X 3/4, SOCKET HEAD CAP
3	2	ECG48	GASKET - END CAP, 1/2", 3/4" & 1" VALVE
2	6	V-30	O-RING, BUNA-N, 70 DURO, AS-220, (REF 1-3/8 X 1-5/8 X 1/8), 3/4" & 1" VALVES
1	1	B6-1	BODY, 3/4" SIDE PORT, UPPER PILOTS, ANODIZED
FLG	QTY	PART NO	DESCRIPTION

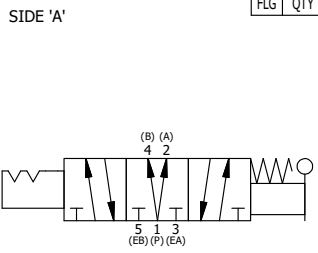
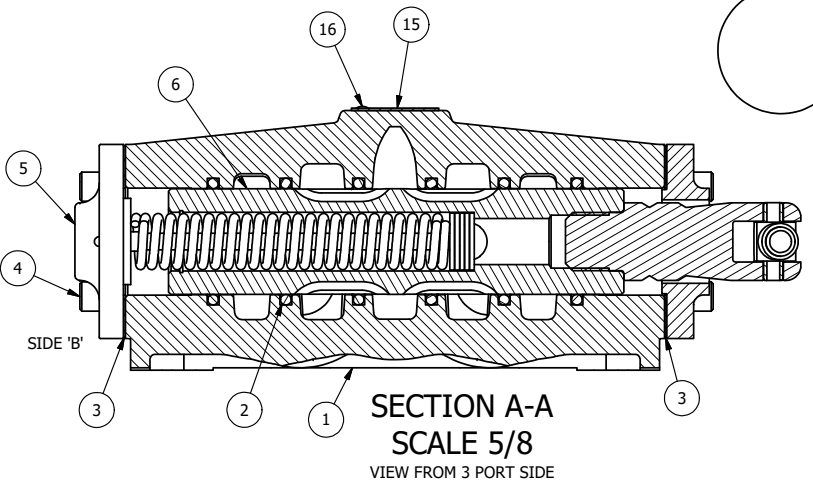

LIMITS ON DIMENSIONS UNLESS OTHERWISE SPECIFIED		2-PL DECIMAL ± .01 3-PL DECIMAL ± .005 FRACTIONAL ± 1/64 ANGULAR ± 1/2°		AAA PRODUCTS INTERNATIONAL 7114 Harry Hines Blvd Dallas, TX 75235
DRAWN: RMckenna	DATE: 2/27/2016	CHECKED: KWaite	DATE: 2/27/2016	
SCALE: 3/4	SHEET: 1 OF 1	RELEASED: HWomack	DATE: 2/27/2016	
TITLE: 3/4" SIDE PORT, LEVER, 3 POS, DETENT C, SPR CTR FROM A, REGEN CTR SPL, 270D LEVER			PART NO.: HW6DRT	REV.:

THE INFORMATION CONTAINED WITHIN THIS DOCUMENT IS PROPRIETARY TO AAA PRODUCTS AND MAY NOT BE DISCLOSED WITHOUT PRIOR WRITTEN CONSENT

D:\Engineering\product\Valve Assembly\Level HW6DRT.dwg