

POSITION GASKET ON END OF VALVE SO  
GASKET COVERS PILOT HOLE  
BOTH SIDES (SIDE 'A' SHOWN)

- NOTES:  
 1) ALWAYS GIVE VALVE MODEL AND PART NUMBER WHEN ORDERING PARTS.  
 2) LUBRICATE DETENT BALL, SPRING AND CLEVIS.

16	2	V-212	SCREW, #2 X 3/16 DRIVE, TYPE U, OVAL HEAD, STAINLESS STEEL
15	1	AN-114	NAMEPLATE, BLANK, FOR VALVES WITH SPRINGS OR DETENTS
14	1	SC4-331VY	CLEVIS - 331VY, 189VY ACTION, STAINLESS, 1/2" VALVE
13	1	V-7	PIN, ROLL 3/16 X 11/16, STEEL, FOR 1/4 THRU 1/2" HAND, FT & CAM V
12	1	V-10	PIN, ROLL 3/16 X 7/8, STEEL
11	1	HL4-9C	HAND LEVER ASSEMBLY, CURVED LEVER, 1/2" VALVE
10	1	FE4-3	END CAP - HAND & FOOT, DETENT, 380 AL, 1/2" VALVE
9	1	V-8	SCREW, 5/16-18 X 5/16, SOCKET SET, CUP POINT
8	1	DS48	SPRING - DETENT, 1/2", 3/4" & 1" VALVE
7	1	V-4	BALL, CHROME STEEL 1/4 DIA. FOR DETENT
6	1	SSH4G	SPOOL - 'G', 3 POS, FLOAT CTR, 1/2" VALVE
5	1	AY-HW4	ASSY - SPR CTR FROM A, 189VY ACTION, 1/2" VALVE
4	8	V-46	SCREW, 1/4-20 X 3/4, SOCKET HEAD CAP
3	2	ECG48	GASKET - END CAP, 1/2", 3/4" & 1" VALVE
2	6	V-6	O-RING, BUNA-N, 70 DURO, AS-216, (REF 1-1/8 X 1-3/8 X 1/8), 1/2" VALVES, 1" SUBPLATE
1	1	B4-1	BODY, 1/2" SIDE PORT, UPPER PILOTS, ANODIZED
FLG	QTY	PART NO	DESCRIPTION

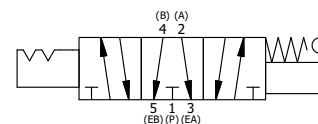
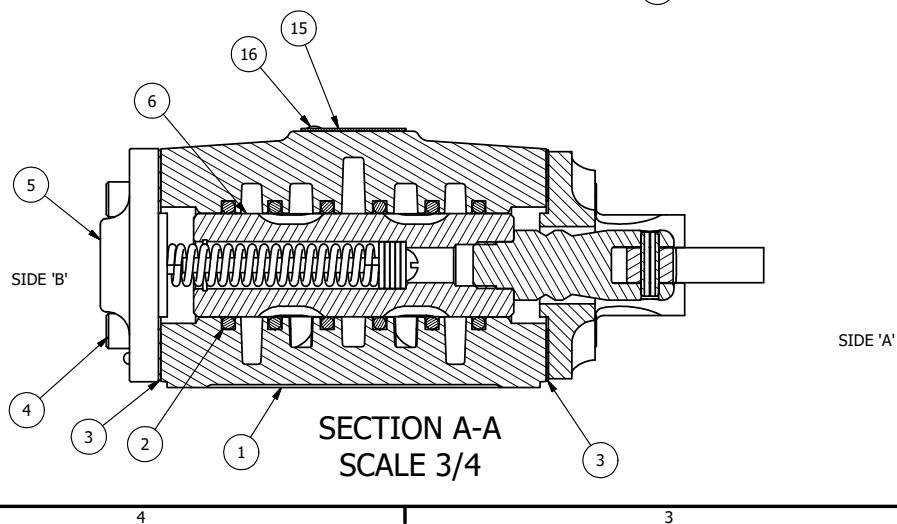

LIMITS ON DIMENSIONS UNLESS OTHERWISE SPECIFIED		2-PL DECIMAL ± .01 3-PL DECIMAL ± .005 FRACTIONAL ± 1/64 ANGULAR ± 1/2°	<b>AAA PRODUCTS INTERNATIONAL</b> 7114 Harry Hines Blvd Dallas, TX 75235	
DRAWN: RMckenna	DATE: 2/3/2025	CHECKED: KWaite	DATE: 2/3/2025	
SCALE: 3/4	SHEET: 1 OF 1	RELEASED: HWomack	DATE: 2/3/2025	
TITLE: 1/2" SIDE PORT, LEVER, 3 POS, DTNT C, REGEN SPR CTR FRM A, CRVD LVR, 90D LVR			PART NO.: HW4GCR	REV.:

THE INFORMATION CONTAINED WITHIN THIS DOCUMENT IS PROPRIETARY TO AAA PRODUCTS AND MAY NOT BE DISCLOSED WITHOUT PRIOR WRITTEN CONSENT

D:\Engineering\Products\Valves\Assembly\lever\HW4GCR.dwg