

POSITION GASKET ON END OF VALVE SO MOUNTING HOLES ALIGN BOTH ENDS (SIDE 'A' SHOWN)

NOTES:
 1) ALWAYS GIVE VALVE MODEL, AND PART NUMBER WHEN ORDERING PARTS.
 2) LUBRICATE DETENT BALL, SPRING AND CLEVIS.

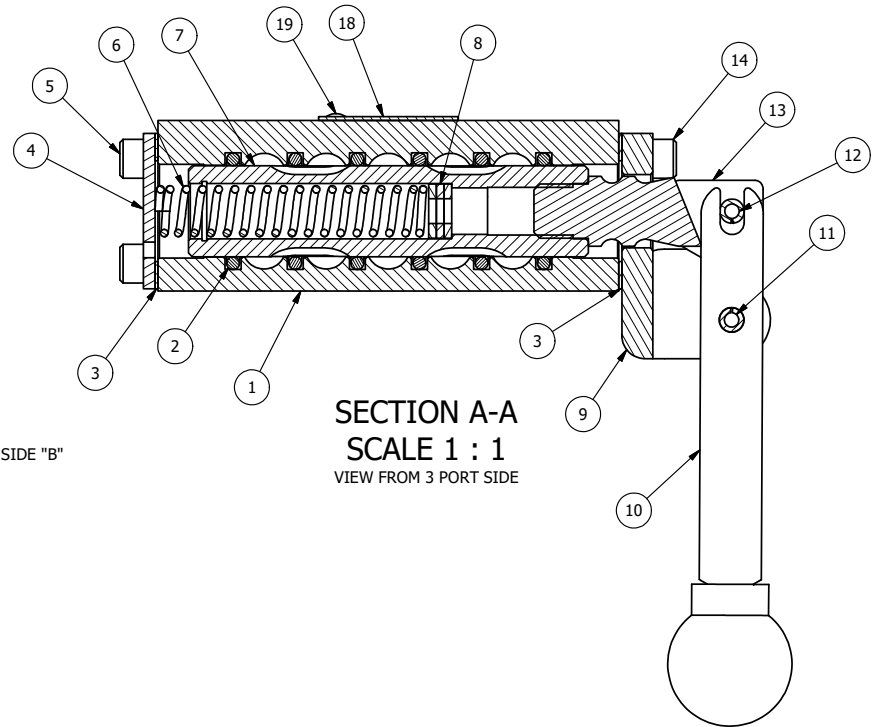

SECTION A-A
 SCALE 1 : 1
 VIEW FROM 3 PORT SIDE

| | | | |
|-----|-----|---------|---|
| 19 | 2 | V-212 | SCREW, #2 X 3/16 DRIVE, TYPE U, OVAL HEAD, STAINLESS STEEL |
| 18 | 1 | AN-114 | NAMEPLATE, BLANK, FOR VALVES WITH SPRINGS OR DETENTS |
| 17 | 2 | V-14 | BALL, CHROME STEEL 3/16 DIA, GRADE 25, FOR DETENT |
| 16 | 2 | DS3 | SPRING - DETENT, 1/4" & 3/8" VALVE |
| 15 | 2 | V-21 | SCREW, 1/4-20 X 3/16, SOCKET SET, CUP POINT |
| 14 | 4 | V-162 | SCREW, 10-24 X 5/8, SOCKET HEAD CAP |
| 13 | 1 | HC3-189 | CLEVIS - HAND, STAINLESS, 189VY ACTION, 1/4" & 3/8" VALVE |
| 12 | 1 | V-48 | PIN, ROLL 3/16 X 9/16, STEEL, ZINC PLATED |
| 11 | 1 | V-508 | PIN, ROLL 3/16 X 5/8 ZINC PLATED STEEL FOR 1/4 FOOT ENDCAP |
| 10 | 1 | HL3-24 | HAND LEVER WITH KNOB, 1/4" & 3/8" VALVE |
| 9 | 1 | HE3-5DD | END CAP, LEVER, DOUBLE DETENT, 303 STAINLESS STEEL, 1/4" & 3/8" VALVE |
| 8 | 3 | V-43 | WASHER - SPRING CTR, 302/304 STAINLESS STEEL, 1/4" & 3/8" VALVES |
| 7 | 1 | SSH3G | SPOOL - 'G', 3 POS, FLOAT CTR, 1/4" & 3/8" VALVE |
| 6 | 1 | CS3-1 | SPRING - CENTERING, 1/4" & 3/8" VALVES |
| 5 | 4 | V-37 | SCREW, 10-24 X 1/2, SOCKET HEAD CAP |
| 4 | 1 | SEC3 | END CAP, 304 STAINLESS STEEL, 1/4" & 3/8" VALVE |
| 3 | 2 | ECG3 | GASKET - END CAP, 1/4" & 3/8" VALVE |
| 2 | 6 | V-39 | O-RING, VITON, STD BODY, 1/4" & 3/8" VALVES |
| 1 | 1 | B3-2E | BODY - SOLID, PLAIN, NO PILOTS, ANODIZED, 3/8" SIDE PORT VALVE |
| FLG | QTY | PART NO | DESCRIPTION |

LIMITS ON DIMENSIONS
 UNLESS OTHERWISE SPECIFIED
 2-PL DECIMAL ± .01
 3-PL DECIMAL ± .005
 FRACTIONAL ± 1/64
 ANGULAR ± 1/2°



DRAWN: RMckenna DATE: 2/3/2025 CHECKED: KWaite DATE: 2/3/2025
 SCALE: 1 : 1 SHEET: 1 OF 1 RELEASED: HWomack DATE: 2/3/2025

| | | |
|---|---------------------|-------|
| TITLE: 3/8" SIDE PORT, LEVER, 3 POS, DTNT C, REGEN SPR CTR FRM A, HVY DUTY, 180D LVR | PART NO.: HW3GHT | REV.: |
|---|---------------------|-------|

THE INFORMATION CONTAINED WITHIN THIS DOCUMENT IS PROPRIETARY TO AAA PRODUCTS AND MAY NOT BE DISCLOSED WITHOUT PRIOR WRITTEN CONSENT

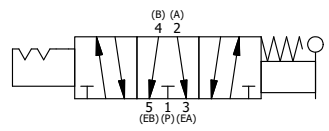

P:\Engineering\product\valves\assembly\lever\HW3GHT.dwg