

4 | 3 | 2 | 1

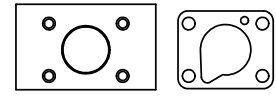

POSITION GASKET ON END OF VALVE SO MOUNTING HOLES ALIGN BOTH ENDS (SIDE 'A' SHOWN)

NOTES:  
 1) ALWAYS GIVE VALVE MODEL, AND PART NUMBER WHEN ORDERING PARTS.  
 2) LUBRICATE DETENT BALL, SPRING AND CLEVIS.

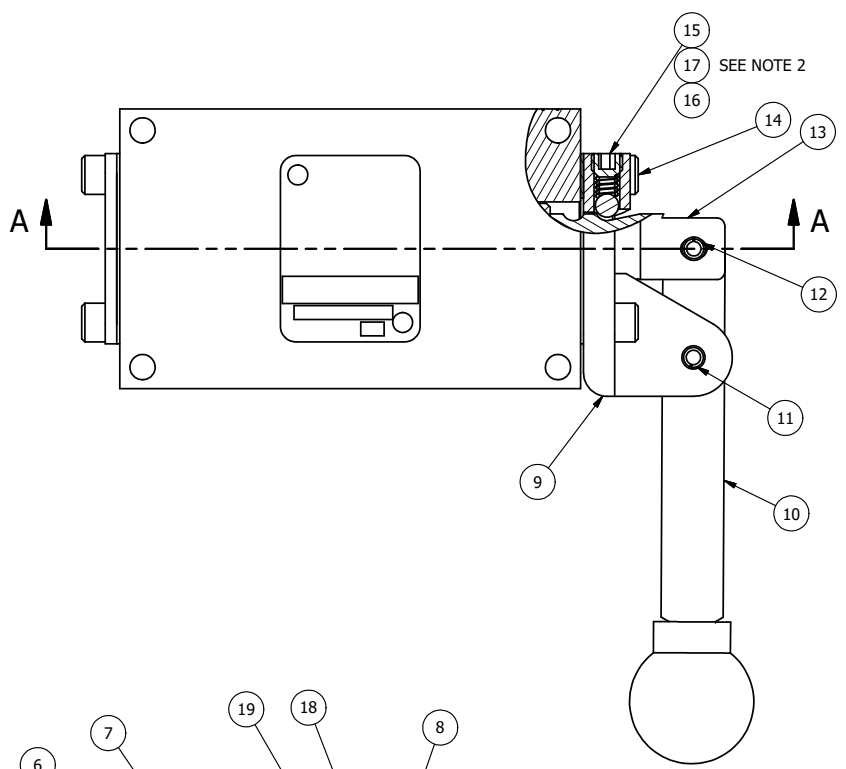
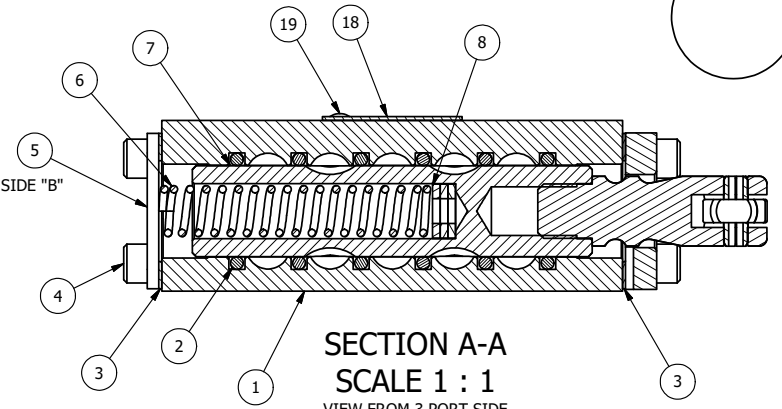

SECTION A-A  
 SCALE 1 : 1  
 VIEW FROM 3 PORT SIDE

SIDE "A"

19	2	V-212	SCREW, #2 X 3/16 DRIVE, TYPE U, OVAL HEAD, STAINLESS STEEL
18	1	AN-114	NAMEPLATE, BLANK, FOR VALVES WITH SPRINGS OR DETENTS
17	1	V-14	BALL, CHROME STEEL 3/16 DIA, GRADE 25, FOR DETENT
16	1	DS3	SPRING - DETENT, 1/4" & 3/8" VALVE
15	1	V-21	SCREW, 1/4-20 X 3/16, SOCKET SET, CUP POINT
14	4	V-162	SCREW, 10-24 X 5/8, SOCKET HEAD CAP
13	1	HC3-189	CLEVIS - HAND, 189VY ACTION, 1/4" & 3/8" VALVE
12	1	V-48	PIN, ROLL 3/16 X 9/16, STEEL, ZINC PLATED
11	1	V-542	PIN, ROLL 3/16 X 1/2 ZINC PLATED STEEL FOR HE3-4 END CAP
10	1	HL3-24	HAND LEVER WITH KNOB, 1/4" & 3/8" VALVE
9	1	HE3-4D	ENDCAP - HAND, DETENT, 303 STAINLESS, 1/4" & 3/8" STACK VALVE
8	3	V-43	WASHER - SPRING CTR, 302/304 STAINLESS STEEL, 1/4" & 3/8" VALVES
7	1	S3	SPOOL - STANDARD, 2 POS, CLSD CTR, 1/4" & 3/8" VALVE
6	1	CS3-1	SPRING - CENTERING, 1/4" & 3/8" VALVES
5	1	SEC3	END CAP, 304 STAINLESS STEEL, 1/4" & 3/8" VALVE
4	4	V-37	SCREW, 10-24 X 1/2, SOCKET HEAD CAP
3	2	ECG3	GASKET - END CAP, 1/4" & 3/8" VALVE
2	6	V-39	O-RING, VITON, STD BODY, 1/4" & 3/8" VALVES
1	1	B2-2E	BODY - SOLID, PLAIN, NO PILOTS, ANODIZED, 1/4" SIDE PORT VALVE
FLG	QTY	PART NO	DESCRIPTION

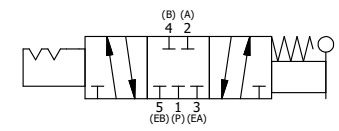

LIMITS ON DIMENSIONS UNLESS OTHERWISE SPECIFIED		2-PL DECIMAL ± .01 3-PL DECIMAL ± .005 FRACTIONAL ± 1/64 ANGULAR ± 1/2°		<b>AAA PRODUCTS INTERNATIONAL</b> 7114 Harry Hines Blvd Dallas, TX 75235
DRAWN: RMckenna	DATE: 2/25/2016	CHECKED: KWaite	DATE: 2/25/2016	
SCALE: 1 : 1	SHEET: 1 OF 1	RELEASED: HWomack	DATE: 2/25/2016	
TITLE: 1/4" SIDE PORT, LEVER, 3 POS, DETENT C, SPR CTR FROM A, CLSD CTR SPL, 270D LEVER			PART NO.: HW2RT	REV.:

THE INFORMATION CONTAINED WITHIN THIS DOCUMENT IS PROPRIETARY TO AAA PRODUCTS AND MAY NOT BE DISCLOSED WITHOUT PRIOR WRITTEN CONSENT

B  
A

4 | 3 | 2 | 1

P:\Engineering\product\Valve Assembly\Level\HW2RT.dwg