

POSITION GASKET ON END OF VALVE SO MOUNTING HOLES ALIGN BOTH ENDS (SIDE 'A' SHOWN)

NOTES:  
 1) ALWAYS GIVE VALVE MODEL, AND PART NUMBER WHEN ORDERING PARTS.  
 2) LUBRICATE DETENT BALL, SPRING AND CLEVIS.

|     |     |            |  |
|-----|-----|------------|--|
| 19  | 2   | V-212      | SCREW, #2 X 3/16 DRIVE, TYPE U, OVAL HEAD, STAINLESS STEEL         |
| 18  | 1   | AN-114     | NAMEPLATE, BLANK, FOR VALVES WITH SPRINGS OR DETENTS               |
| 17  | 1   | V-14       | BALL, CHROME STEEL 3/16 DIA, GRADE 25, FOR DETENT                  |
| 16  | 1   | DS3        | SPRING - DETENT, 1/4" & 3/8" VALVE                                 |
| 15  | 1   | V-21       | SCREW, 1/4-20 X 3/16, SOCKET SET, CUP POINT                        |
| 14  | 4   | V-162      | SCREW, 10-24 X 5/8, SOCKET HEAD CAP                                |
| 13  | 1   | HC3-189    | CLEVIS - HAND, STAINLESS, 189VY ACTION, 1/4" & 3/8" VALVE          |
| 12  | 1   | V-48       | PIN, ROLL 3/16 X 9/16, STEEL, ZINC PLATED                          |
| 11  | 1   | V-542      | PIN, ROLL 3/16 X 1/2 ZINC PLATED STEEL FOR HE3-4 END CAP           |
| 10  | 1   | HL3-521B20 | HAND LEVER WITH RED KNOB, BENT 20 DEG SIDEWAYS, 1/4" & 3/8" VALVES |
| 9   | 1   | HE3-4D     | ENDCAP - HAND, DETENT, 303 STAINLESS, 1/4" & 3/8" STACK VALVE      |
| 8   | 3   | V-43       | WASHER - SPRING CTR, 302/304 STAINLESS STEEL, 1/4" & 3/8" VALVES   |
| 7   | 1   | SSH3G      | SPOOL - 'G', 3 POS, FLOAT CTR, 1/4" & 3/8" VALVE                   |
| 6   | 1   | CS3-1      | SPRING - CENTERING, 1/4" & 3/8" VALVES                             |
| 5   | 1   | SEC3       | END CAP, 304 STAINLESS STEEL, 1/4" & 3/8" VALVE                    |
| 4   | 4   | V-37       | SCREW, 10-24 X 1/2, SOCKET HEAD CAP                                |
| 3   | 2   | ECG3       | GASKET - END CAP, 1/4" & 3/8" VALVE                                |
| 2   | 6   | V-39       | O-RING, VITON, STD BODY, 1/4" & 3/8" VALVES                        |
| 1   | 1   | B2-2E      | BODY - SOLID, PLAIN, NO PILOTS, ANODIZED, 1/4" SIDE PORT VALVE     |
| FLG | QTY | PART NO    | DESCRIPTION  |

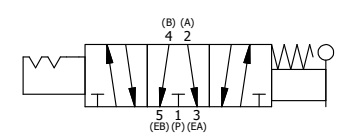
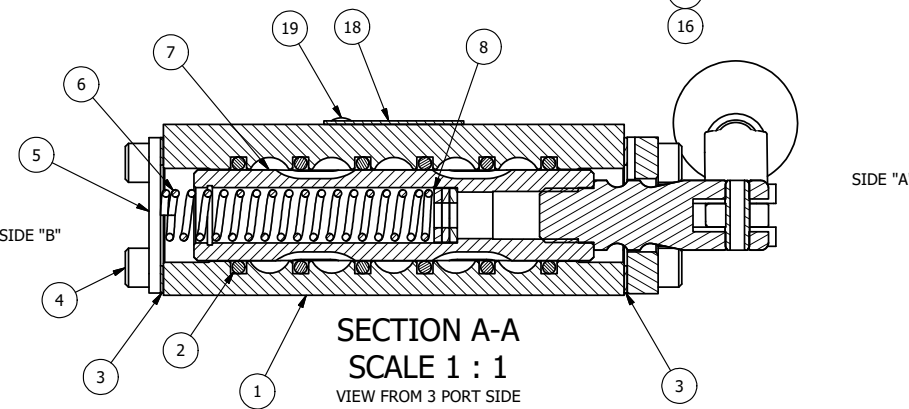

|  |                |  |                |  |
|--|----------------|--|----------------|--|
| LIMITS ON DIMENSIONS<br>UNLESS OTHERWISE SPECIFIED   |                | 2-PL DECIMAL ± .01<br>3-PL DECIMAL ± .005<br>FRACTIONAL ± 1/64<br>ANGULAR ± 1/2° |                | <b>AAA PRODUCTS INTERNATIONAL</b><br>7114 Harry Hines Blvd<br>Dallas, TX 75235 |
| DRAWN: RMckenna  | DATE: 2/3/2025 | CHECKED: KWaite  | DATE: 2/3/2025 |  |
| SCALE: 1 : 1   | SHEET: 1 OF 1  | RELEASED: HWomack  | DATE: 2/3/2025 | PART NO.: HW2GBLJR   |
| TITLE:<br><b>1/4" SIDE PORT, LEVER, 3 POS, DTNT C, REGEN SPR CTR FRM A, BNT LVR LFT, RED KNOB, 90D LVR</b> |                |  |                | REV.:  |

THE INFORMATION CONTAINED WITHIN THIS DOCUMENT IS PROPRIETARY TO AAA PRODUCTS AND MAY NOT BE DISCLOSED WITHOUT PRIOR WRITTEN CONSENT

P:\Engineering\product\valves\assembly\lever\HW2GBLJR.dwg