

POSITION GASKET ON END OF VALVE SO MOUNTING HOLES ALIGN BOTH ENDS (SIDE 'A' SHOWN)

NOTES:  
1) ALWAYS GIVE VALVE MODEL, AND PART NUMBER WHEN ORDERING PARTS.  
2) LUBRICATE DETENT BALL, SPRING AND CLEVIS.

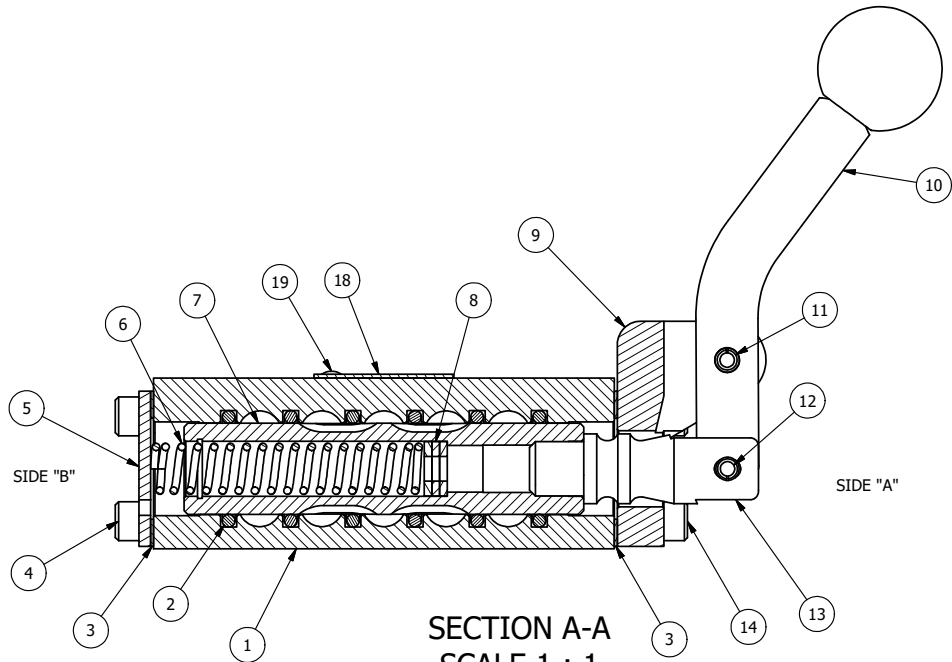

SECTION A-A  
SCALE 1 : 1  
VIEW FROM 3 PORT SIDE

|     |     |          |   |
|-----|-----|----------|---|
| 19  | 2   | V-212    | SCREW, #2 X 3/16 DRIVE, TYPE U, OVAL HEAD, STAINLESS STEEL        |
| 18  | 1   | AN-114   | NAMEPLATE, BLANK, FOR VALVES WITH SPRINGS OR DETENTS              |
| 17  | 2   | V-14     | BALL, CHROME STEEL 3/16 DIA, GRADE 25, FOR DETENT                 |
| 16  | 2   | DS3      | SPRING - DETENT, 1/4" & 3/8" VALVE                                |
| 15  | 2   | V-21     | SCREW, 1/4-20 X 3/16, SOCKET SET, CUP POINT                       |
| 14  | 4   | V-38     | SCREW, 10-24 X 3/4, SOCKET HEAD CAP                               |
| 13  | 1   | HC3-189  | CLEVIS - HAND, STAINLESS, 189VY ACTION, 1/4" & 3/8" VALVE         |
| 12  | 1   | V-48     | PIN, ROLL 3/16 X 9/16, STEEL, ZINC PLATED                         |
| 11  | 1   | V-7      | PIN, ROLL 3/16 X 11/16, STEEL, FOR 1/4 THRU 1/2" HAND, FT & CAM V |
| 10  | 1   | HL3-521C | CURVED HAND LEVER WITH RED KNOB, 1/4" & 3/8" VALVE                |
| 9   | 1   | HE3-3DD  | END CAP, LEVER, DOUBLE DETENT, 380 AL, 1/4" & 3/8" VALVE          |
| 8   | 3   | V-43     | WASHER - SPRING CTR, 302/304 STAINLESS STEEL, 1/4" & 3/8" VALVES  |
| 7   | 1   | SSH3D    | SPOOL - 'D', 3 POS, REGEN CTR, 1/4" & 3/8" VALVE                  |
| 6   | 1   | CS3-1    | SPRING - CENTERING, 1/4" & 3/8" VALVES                            |
| 5   | 1   | SEC3     | END CAP, 304 STAINLESS STEEL, 1/4" & 3/8" VALVE                   |
| 4   | 4   | V-37     | SCREW, 10-24 X 1/2, SOCKET HEAD CAP                               |
| 3   | 2   | ECG3     | GASKET - END CAP, 1/4" & 3/8" VALVE                               |
| 2   | 6   | V-39     | O-RING, VITON, STD BODY, 1/4" & 3/8" VALVES                       |
| 1   | 1   | B2-2E    | BODY - SOLID, PLAIN, NO PILOTS, ANODIZED, 1/4" SIDE PORT VALVE    |
| FLG | QTY | PART NO  | DESCRIPTION   |

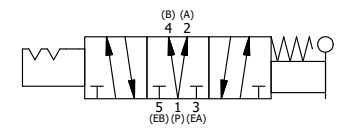

|   |                |  |                     |  |
|---|----------------|--|---------------------|--|
| LIMITS ON DIMENSIONS<br>UNLESS OTHERWISE SPECIFIED  |                | 2-PL DECIMAL ± .01<br>3-PL DECIMAL ± .005<br>FRACTIONAL ± 1/64<br>ANGULAR ± 1/2° |                     | <b>AAA PRODUCTS INTERNATIONAL</b><br>7114 Harry Hines Blvd<br>Dallas, TX 75235 |
| DRAWN: RMckenna   | DATE: 2/2/2025 | CHECKED: KWaite  | DATE: 2/2/2025      |  |
| SCALE: 1 : 1  | SHEET: 1 OF 1  | RELEASED: HWomack  | DATE: 2/2/2025      |  |
| TITLE:<br>1/4" SIDE PORT, LEVER, 3 POS,<br>DTNT C, REGEN SPR CTR FRM A,<br>CRVD LVR, RED KNOB |                |  | PART NO.:<br>HW2DCJ | REV.:  |

THE INFORMATION CONTAINED WITHIN THIS DOCUMENT IS PROPRIETARY TO AAA PRODUCTS AND MAY NOT BE DISCLOSED WITHOUT PRIOR WRITTEN CONSENT

P:\Engineering\Products\Valves\Assembly\lever\HW2DCJ.dwg