

POSITION GASKET ON END OF VALVE TO SEAL PILOT HOLE IF PRESENT, BOTH SIDES (SIDE 'B' SHOWN)

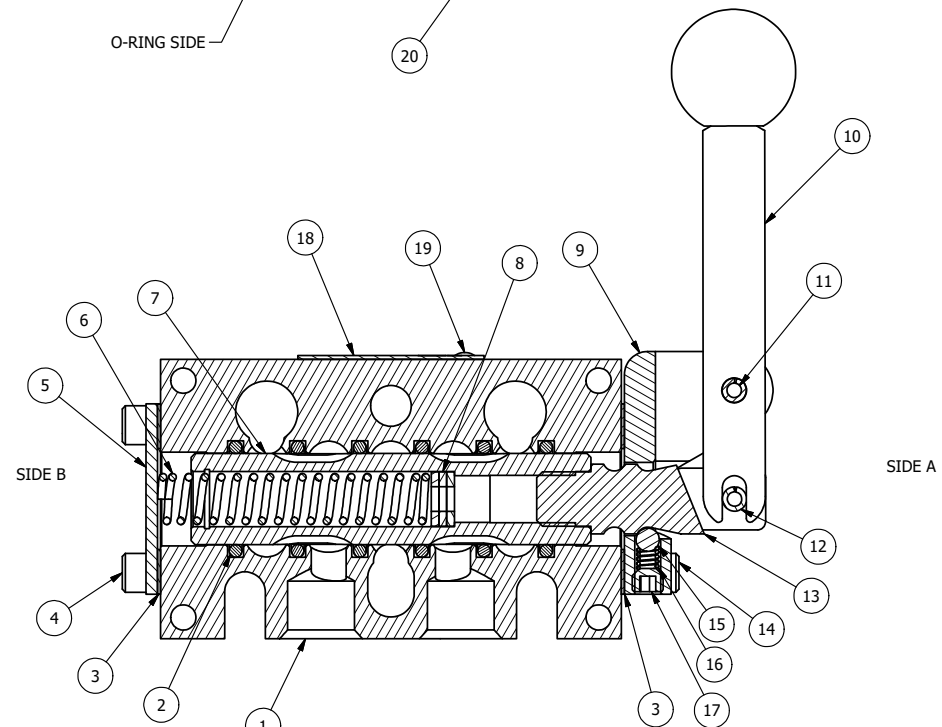

SECTION A-A  
SCALE 1 : 1

NOTES:  
1) ALWAYS GIVE VALVE MODEL AND PART NUMBER WHEN ORDERING PARTS.

|     |     |         |   |
|-----|-----|---------|---|
| 20  | 3   | V-110   | O-RING, BUNA-N, 70 DURO, AS-114, (REF 5/8 X 13/16 X 3/32), 1/4" SLEEVE, 1/2" SUB, STACK |
| 19  | 2   | V-212   | SCREW, #2 X 3/16 DRIVE, TYPE U, OVAL HEAD, STAINLESS STEEL                              |
| 18  | 1   | AN-114  | NAMEPLATE, BLANK, FOR VALVES WITH SPRINGS OR DETENTS                                    |
| 17  | 1   | V-21    | SCREW, 1/4-20 X 3/16, SOCKET SET, CUP POINT   |
| 16  | 1   | DS3     | SPRING - DETENT, 1/4" & 3/8" VALVE  |
| 15  | 1   | V-14    | BALL, CHROME STEEL 3/16 DIA, GRADE 25, FOR DETENT                                       |
| 14  | 4   | V-162   | SCREW, 10-24 X 5/8, SOCKET HEAD CAP   |
| 13  | 1   | HC3-189 | CLEVIS - HAND, 189VY ACTION, 1/4" & 3/8" VALVE  |
| 12  | 1   | V-48    | PIN, ROLL 3/16 X 9/16, STEEL, ZINC PLATED   |
| 11  | 1   | V-542   | PIN, ROLL 3/16 X 1/2 ZINC PLATED STEEL FOR HE3-4 END CAP                                |
| 10  | 1   | HL3-521 | HAND LEVER WITH RED KNOB, 1/4" & 3/8" VALVE   |
| 9   | 1   | HE3-4D  | ENDCAP - HAND, DETENT, 303 STAINLESS, 1/4" & 3/8" STACK VALVE                           |
| 8   | 3   | V-43    | WASHER - SPRING CTR, 302/304 STAINLESS STEEL, 1/4" & 3/8" VALVES                        |
| 7   | 1   | SSH3G   | SPOOL - 'G', 3 POS, FLOAT CTR, 1/4" & 3/8" VALVE  |
| 6   | 1   | CS3-1   | SPRING - CENTERING, 1/4" & 3/8" VALVES  |
| 5   | 1   | SEC3    | END CAP, 304 STAINLESS STEEL, 1/4" & 3/8" VALVE   |
| 4   | 4   | V-37    | SCREW, 10-24 X 1/2, SOCKET HEAD CAP   |
| 3   | 2   | ECG3    | GASKET - END CAP, 1/4" & 3/8" VALVE   |
| 2   | 6   | V-39    | O-RING, VITON, STD BODY, 1/4" & 3/8" VALVES   |
| 1   | 1   | B3-10E  | FINISHED - SOLID BODY, UPPER PILOTS, 3/8" STACKING VALVE                                |
| FLG | QTY | PART NO | DESCRIPTION   |

|  |                 |  |                 |  |
|--|-----------------|--|-----------------|--|
| LIMITS ON DIMENSIONS<br>UNLESS OTHERWISE SPECIFIED   |                 | 2-PL DECIMAL ± .01<br>3-PL DECIMAL ± .005<br>FRACTIONAL ± 1/64<br>ANGULAR ± 1/2° |                 | <b>AAA PRODUCTS INTERNATIONAL</b><br>7114 Harry Hines Blvd<br>Dallas, TX 75235 |
| DRAWN: RMckenna  | DATE: 2/27/2016 | CHECKED: KWaite  | DATE: 2/27/2016 |  |
| SCALE: 1 : 1   | SHEET: 1 OF 1   | RELEASED: HWomack  | DATE: 2/27/2016 |  |
| TITLE:<br><b>3/8" STACK, LEVER, 3 POS, DETENT C, SPR CTR FROM A, FLOAT CTR SPL, RED KNOB</b> |                 | PART NO.:<br><b>BHW3GJ</b>   | REV.:           |  |

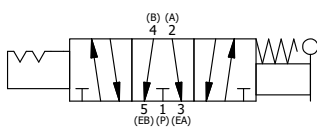

THE INFORMATION CONTAINED WITHIN THIS DOCUMENT IS PROPRIETARY TO AAA PRODUCTS AND MAY NOT BE DISCLOSED WITHOUT PRIOR WRITTEN CONSENT

D:\Engineering\product\Valve Assembly\Level HW3G\BHW3GJ.dwg