

4 | 3 | 2 | 1

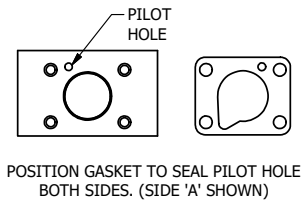

NOTES:
1) ALWAYS GIVE VALVE MODEL, AND PART NUMBER WHEN ORDERING PARTS.

17	1	ZNSPK-2	KIT - SUBPLATE MOUNTING, BRASS NAMUR, (2 EA V-618-SS SCREW, 2 EA V-565 O-RING)
16	1	V-548	O-RING, BUNA-N, 70 DURO, 6MM X 1MM, NAMUR PLUG
15	1	V-547	PLUG, 360 HALF HARD BRASS, NAMUR VALVE
14	4	V-162-SS	SCREW, 10-24 X 5/8, SOCKET HEAD CAP, STAINLESS STEEL
13	1	HC3	CLEVIS - NO DETENTS, STAINLESS, 1/4" & 3/8" VALVE
12	1	V-48-SS	PIN, ROLL 3/16 X 9/16 18-8 STAINLESS
11	1	V-542-SS	PIN, ROLL 3/16 X 1/2 NON-MAGNETIC STAINLESS STEEL FOR HE3-4 END CAP
10	1	HL3-SS	HAND LEVER, 303 STAINLESS STEEL, 1/4" & 3/8" VALVE
9	1	V-580	KNOB, BLACK (BRASS 3/8-16 INSERT), 1" DIA BALL
8	1	HE3-4	ENDCAP - HAND OPERATOR, 303 STAINLESS, 1/4" & 3/8" STACK VALVE
7	1	S3	SPOOL - STANDARD, 2 POS, CLSD CTR, 1/4" & 3/8" VALVE
6	1	CS3	SPRING - RETURN, (EXCEPT HO, KO & PO) 1/4" & 3/8" VALVES
5	1	SEC3-3	END CAP, VENTED, STAINLESS STEEL, 1/4" & 3/8" VALVES
4	4	V-38-SS	SCREW, 10-24 X 3/4, SOCKET HEAD CAP, 18-8 SS
3	2	ECG3	GASKET - END CAP, 1/4" & 3/8" VALVE
2	6	V-39	O-RING, VITON, STD BODY, 1/4" & 3/8" VALVES
1	1	Z2-11	BODY - BRASS, UPPER PILOTS (BUTTON BLEEDER), 1/4" NAMUR
FLG	QTY	PART NO	DESCRIPTION

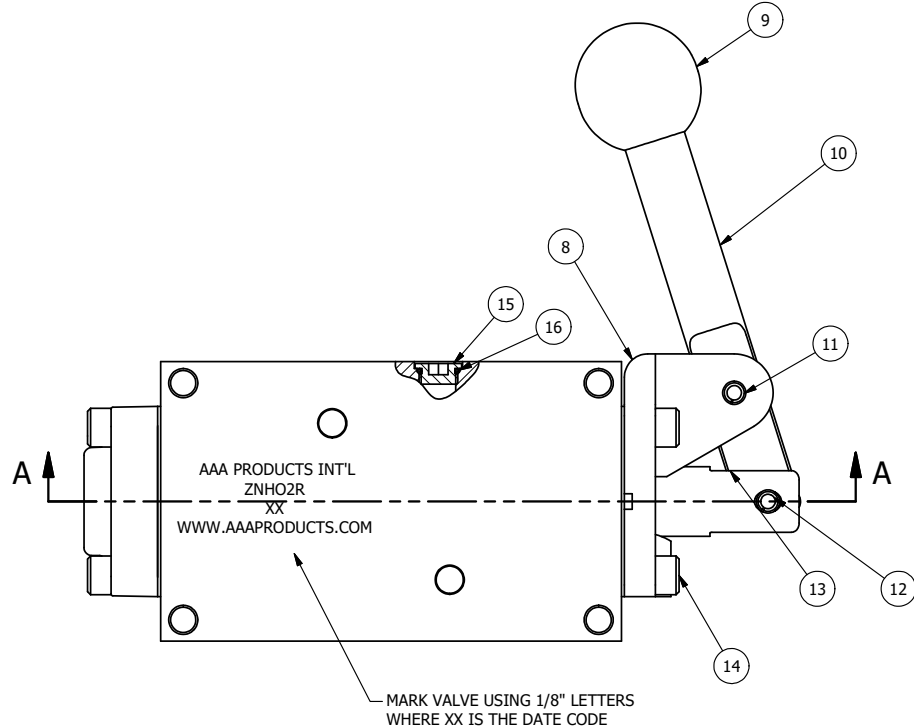
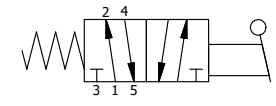
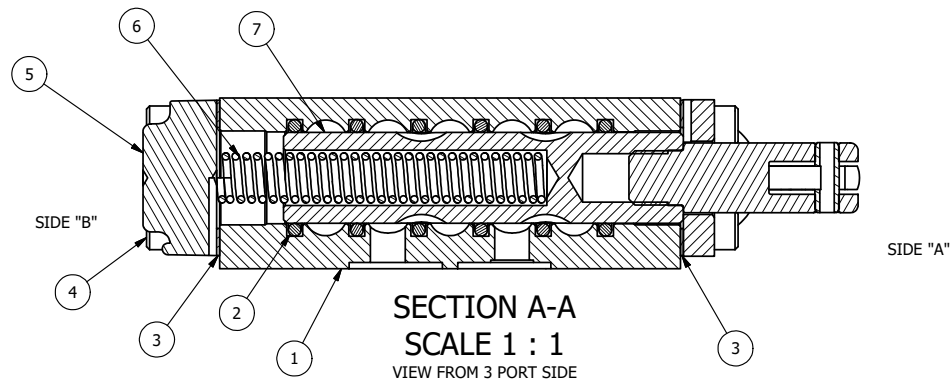

LIMITS ON DIMENSIONS UNLESS OTHERWISE SPECIFIED		2-PL DECIMAL ± .01 3-PL DECIMAL ± .005 FRACTIONAL ± 1/64 ANGULAR ± 1/2°		AAA PRODUCTS INTERNATIONAL 7114 Harry Hines Blvd Dallas, TX 75235	
DRAWN: RMckenna	DATE: 9/8/2015	CHECKED: KWaite	DATE: 9/8/2015		
SCALE: 1 : 1	SHEET: 1 OF 1	RELEASED: HWomack	DATE: 9/8/2015		
TITLE: 1/4" NAMUR, LEVER, 2 POS, SPRING RTRN, BRASS & STAINLESS, 90D LEVER			PART NO.: ZNH02R		REV.:

THE INFORMATION CONTAINED WITHIN THIS DOCUMENT IS PROPRIETARY TO AAA PRODUCTS AND MAY NOT BE DISCLOSED WITHOUT PRIOR WRITTEN CONSENT

B | A

4 | 3 | 2

D:\Engineering\product\Valves\Assembly\Level 1\PSW\ZAH02R.dwg