

POSITION GASKET ON END OF VALVE SO MOUNTING HOLES ALIGN BOTH ENDS (SIDE 'A' SHOWN)

NOTES:
1) ALWAYS GIVE VALVE MODEL, AND PART NUMBER WHEN ORDERING PARTS.

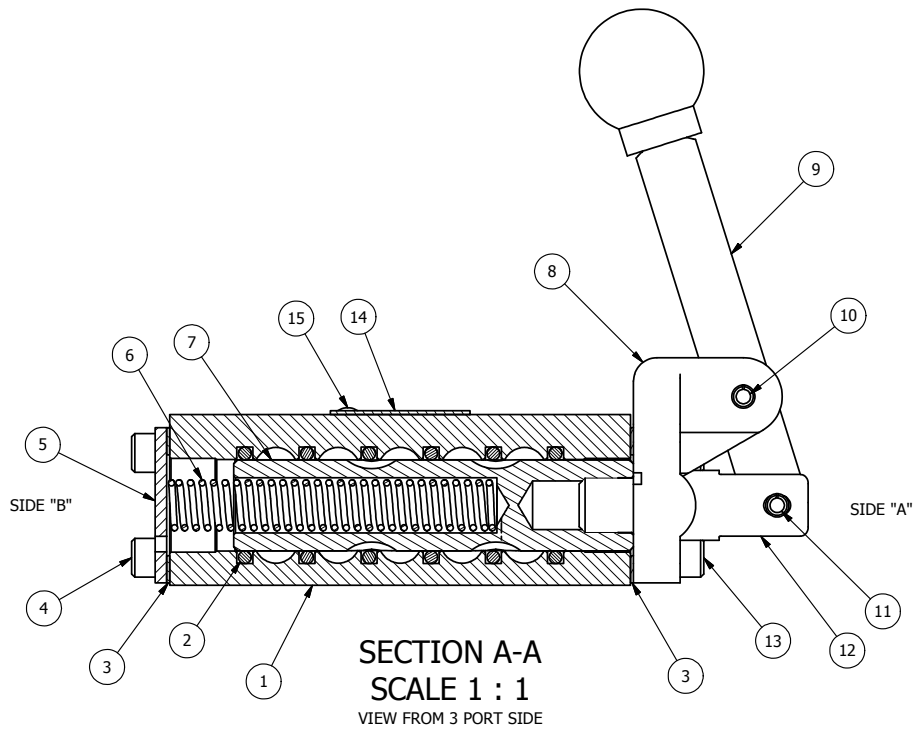

FLG	QTY	PART NO	DESCRIPTION
15	2	V-212	SCREW, #2 X 3/16 DRIVE, TYPE U, OVAL HEAD, 316 STAINLESS STEEL
14	1	AN-114	NAME PLATE, BLANK, FOR VALVES WITH SPRINGS OR DETENTS.
13	4	V-38	SCREW, 10-24 X 3/4 SHCS, FOR 3/8" CAST END CAP
12	1	HC3	CLEVIS - NO DETENTS, 1/4" & 3/8" VALVE
11	1	V-48	PIN, ROLL 3/16 X 9/16 ZINC PLATED STEEL FOR 1/4 HAND & FOOT CLEVIS
10	1	V-7	PIN, ROLL 3/16 X 11/16 FOR 1/4 THRU 1/2" HAND, FT. & CAM V
9	1	HL3-24	HAND LEVER WITH KNOB, 1/4" & 3/8" VALVE
8	1	HE3-1	END CAP, LEVER, 380 AL, 1/4" & 3/8" VALVE
7	1	S3	SPOOL - STANDARD, 2 POS, CLSD CTR, 1/4" & 3/8" VALVE
6	1	CS3-2	SPRING - RETURN, (HO & KO) 1/4" & 3/8" VALVES
5	1	SEC3	END CAP, STEEL, ZINC PLT, 1/4" & 3/8" VALVE
4	4	V-37	SCREW, 10-24 X 1/2 SHCS, FOR 1/8" STEEL END CAPS
3	2	ECG3	GASKET - END CAP, 1/4" & 3/8" VALVE
2	6	V-39	O-RING, STD BODY, VITON, 1/4" & 3/8" VALVES
1	1	B2-2E	BODY - SOLID, PLAIN, NO PILOTS, ANODIZED, 1/4" SIDE PORT VALVE

LIMITS ON DIMENSIONS UNLESS OTHERWISE SPECIFIED		2-PL DECIMAL ± .01 3-PL DECIMAL ± .005 FRACTIONAL ± 1/64 ANGULAR ± 1/2°		AAA PRODUCTS INTERNATIONAL 7114 Harry Hines Blvd Dallas, TX 75235
DRAWN: RHuffstetter		DATE: 4/29/1999		
SCALE: 1 : 1		SHEET: 1 OF 1		DATE: 5/29/2015
TITLE: 1/4" SIDE PORT, LEVER, 2 POS, SPRING RTRN		PART NO.: HO2		REV.: A

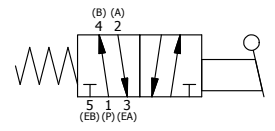

NO.	DATE	REVISION
A	4/19/99	REDRAWN AND CONV TO CAD

THE INFORMATION CONTAINED WITHIN THIS DOCUMENT IS PROPRIETARY TO AAA PRODUCTS AND MAY NOT BE DISCLOSED WITHOUT PRIOR WRITTEN CONSENT

D:\Engineering\Inventory Files\Internal Drawings\Valves Assembly\Lever\HO2.dwg