

POSITION GASKET ON END OF VALVE TO SEAL PILOT HOLE IF PRESENT, BOTH SIDES (SIDE 'B' SHOWN)

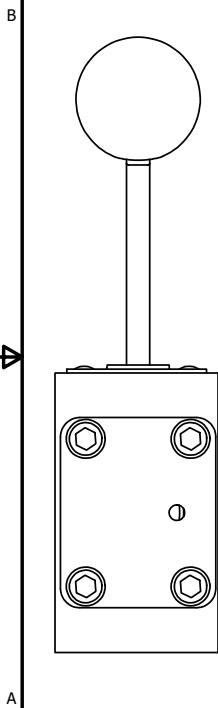

SIDE B

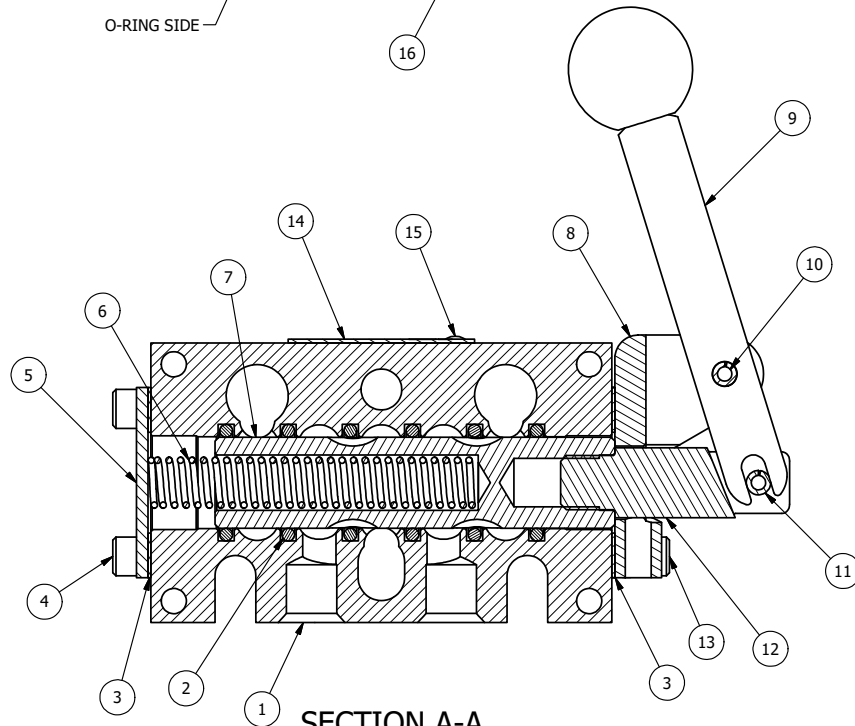

SIDE A

SECTION A-A  
SCALE 1 : 1

NOTES:

1) ALWAYS GIVE VALVE MODEL AND PART NUMBER WHEN ORDERING PARTS.

16	3	V-110	O-RING, BUNA-N, 70 DURO, AS-114, (REF 5/8 X 13/16 X 3/32), 1/4" SLEEVE, 1/2" SUB, STACK
15	2	V-212	SCREW, #2 X 3/16 DRIVE, TYPE U, OVAL HEAD, STAINLESS STEEL
14	1	AN-114	NAMEPLATE, BLANK, FOR VALVES WITH SPRINGS OR DETENTS
13	4	V-162	SCREW, 10-24 X 5/8, SOCKET HEAD CAP
12	1	BHC3	CLEVIS - NO DETENTS, 1/4" & 3/8" STACKING VALVE
11	1	V-48	PIN, ROLL 3/16 X 9/16, STEEL, ZINC PLATED
10	1	V-542	PIN, ROLL 3/16 X 1/2 ZINC PLATED STEEL FOR HE3-4 END CAP
9	1	HL3-521	HAND LEVER WITH RED KNOB, 1/4" & 3/8" VALVE
8	1	HE3-4	ENDCAP - HAND OPERATOR, 303 STAINLESS, 1/4" & 3/8" STACK VALVE
7	1	S3	SPOOL - STANDARD, 2 POS, CLSD CTR, 1/4" & 3/8" VALVE
6	1	CS3-2	SPRING - RETURN, (HO & KO) 1/4" & 3/8" VALVES
5	1	SEC3	END CAP, 304 STAINLESS STEEL, 1/4" & 3/8" VALVE
4	4	V-37	SCREW, 10-24 X 1/2, SOCKET HEAD CAP
3	2	ECG3	GASKET - END CAP, 1/4" & 3/8" VALVE
2	6	V-39	O-RING, VITON, STD BODY, 1/4" & 3/8" VALVES
1	1	B2-10E	FINISHED - SOLID BODY, UPPER PILOTS, 1/4" STACKING VALVE
FLG	QTY	PART NO	DESCRIPTION

LIMITS ON DIMENSIONS  
UNLESS  
OTHERWISE SPECIFIED

2-PL DECIMAL ± .01  
3-PL DECIMAL ± .005  
FRACTIONAL ± 1/64  
ANGULAR ± 1/2°



DRAWN: RMckenna DATE: 9/16/2015

CHECKED: KWaite DATE: 9/16/2015

SCALE: 1 : 1 SHEET: 1 OF 1

RELEASED: HWomack DATE: 9/16/2015

TITLE:  
1/4" STACK, LEVER, 2 POS,  
SPRING RTRN, RED KNOB

PART NO.:

BHO2J

REV.:

