

POSITION GASKET ON END OF VALVE TO SEAL PILOT HOLE IF PRESENT, BOTH SIDES (SIDE 'B' SHOWN)

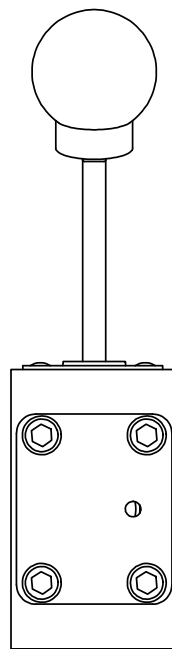

SIDE B

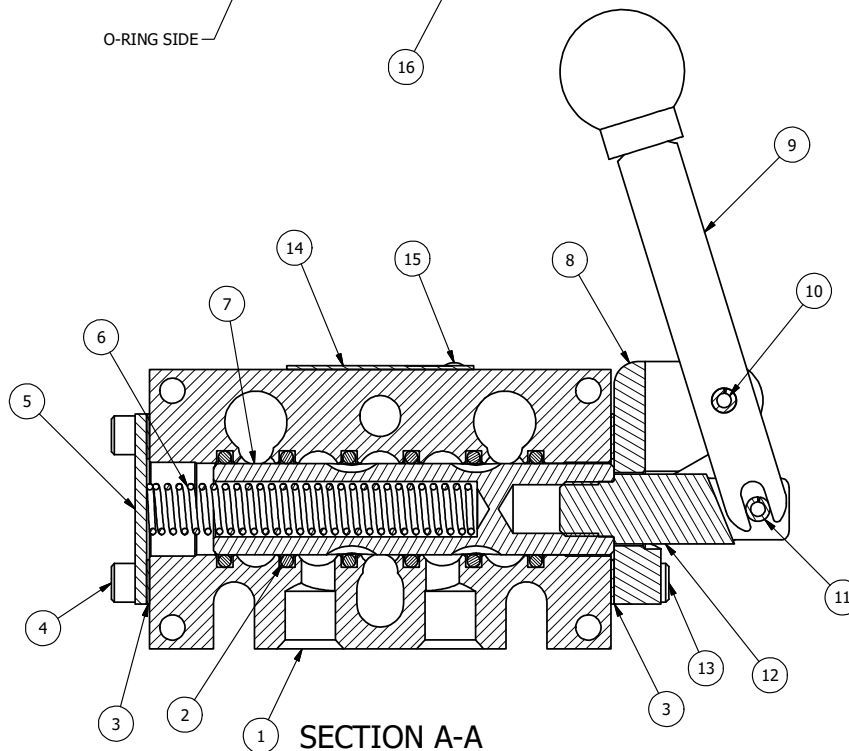

SIDE A

SECTION A-A  
SCALE 1 : 1

NOTES:

1) ALWAYS GIVE VALVE MODEL AND PART NUMBER WHEN ORDERING PARTS.

PLG	QTY	PART NO	DESCRIPTION
16	3	V-110	O-RING, BUNA-N, 70 DURO, AS-114, (REF 5/8 X 13/16 X 3/32), 1/4" SLEEVE, 1/2" SUB, STACK
15	2	V-212	SCREW, 2 X 3/16, DRIVE, TYPE U, OVAL HEAD, 316 SS
14	1	AN-114	NAME PLATE, BLANK, FOR VALVES WITH SPRINGS OR DETENTS.
13	4	V-162	SCREW, 10-24 X 5/8, SOCKET HEAD CAP
12	1	BHC3	CLEVIS - NO DETENTS, 1/4" & 3/8" STACKING VALVE
11	1	V-48	PIN, ROLL 3/16 X 9/16 ZINC PLATED STEEL
10	1	V-542	PIN, ROLL 3/16 X 1/2 ZINC PLATED STEEL FOR HE3-4 END CAP
9	1	HL3-24	HAND LEVER WITH KNOB, 1/4" & 3/8" VALVE
8	1	HE3-4	ENDCAP - HAND OPERATOR, 303 STAINLESS, 1/4" & 3/8" STACK VALVE
7	1	S3	SPOOL - STANDARD, 2 POS, CLSD CTR, 1/4" & 3/8" VALVE
6	1	CS3-2	SPRING - RETURN, (HO & KO) 1/4" & 3/8" VALVES
5	1	SEC3	END CAP, 304 STAINLESS STEEL, 1/4" & 3/8" VALVE
4	4	V-37	SCREW, 10-24 X 1/2, SOCKET HEAD CAP
3	2	ECG3	GASKET - END CAP, 1/4" & 3/8" VALVE
2	6	V-39	O-RING, STD BODY, VITON, 1/4" & 3/8" VALVES
1	1	B2-10E	FINISHED - SOLID BODY, UPPER PILOTS, 1/4" STACKING VALVE
PLG	QTY	PART NO	DESCRIPTION

LIMITS ON DIMENSIONS  
UNLESS OTHERWISE SPECIFIED

2-PL DECIMAL ± .01  
3-PL DECIMAL ± .005  
FRACTIONAL ± 1/64  
ANGULAR ± 1/2°



**AAA PRODUCTS INTERNATIONAL**  
7114 Harry Hines Blvd  
Dallas, TX 75235

DRAWN: RHuffstetter DATE: 3/7/2002  
SCALE: 1 : 1 SHEET: 1 OF 1

CHECKED: KWaitte DATE: 9/29/2013  
RELEASED: HWomack DATE: 9/29/2013

TITLE:  
1/4" STACK, LEVER, 2 POS,  
SPRING RTRN

PART NO.:  
BHO2

REV.:  
B

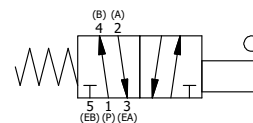

NO.	DATE	REVISION
B	10/17/06	CHANGED GASKET FROM BG3 TO ECG3.
A	7/20/05	CHANGED GASKET FROM NEG3 TO BG3.

THE INFORMATION CONTAINED WITHIN THIS DOCUMENT IS PROPRIETARY TO AAA PRODUCTS AND MAY NOT BE DISCLOSED WITHOUT PRIOR WRITTEN CONSENT

D:\Engineering\Inventor Files\Internal Drawings\Valves Assembly\Level HO (BHO2).dwg