

4 | 3 | 2 | 1

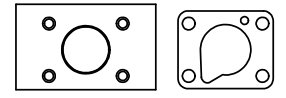

POSITION GASKET ON END OF VALVE SO MOUNTING HOLES ALIGN BOTH ENDS (SIDE 'A' SHOWN)

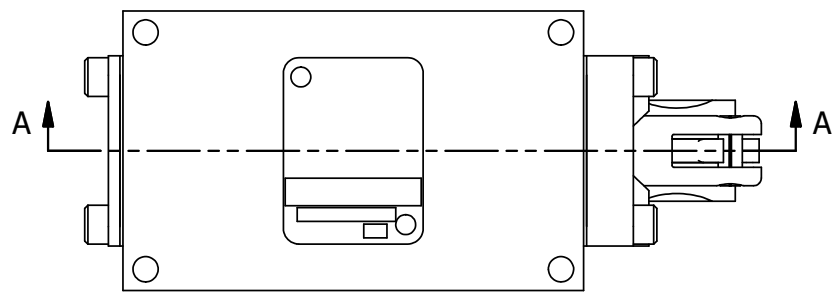
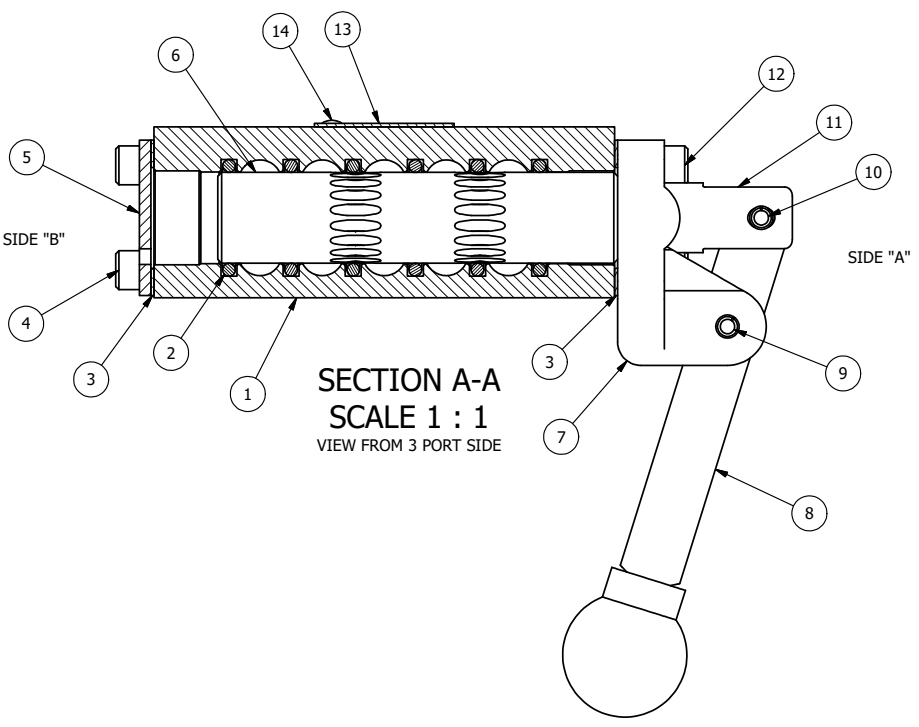

NOTES:
1) ALWAYS GIVE VALVE MODEL, AND PART NUMBER WHEN ORDERING PARTS.

| FLG | QTY | PART NO | DESCRIPTION |
|-----|-----|---------|---|
| 14 | 2 | V-212 | SCREW, #2 X 3/16 DRIVE, TYPE U, OVAL HEAD, STAINLESS STEEL |
| 13 | 1 | AN-115 | BLANK NAMEPLATE FOR HE,KE,KD,RR,D,CR,PP,SR,SS VALVES. |
| 12 | 4 | V-38 | SCREW, 10-24 X 3/4, SOCKET HEAD CAP |
| 11 | 1 | HC3 | CLEVIS - NO DETENTS, 1/4" & 3/8" VALVE |
| 10 | 1 | V-48 | PIN, ROLL 3/16 X 9/16, STEEL, ZINC PLATED |
| 9 | 1 | V-7 | PIN, ROLL 3/16 X 11/16, STEEL, FOR 1/4 THRU 1/2" HAND, FT & CAM V |
| 8 | 1 | HL3-24 | HAND LEVER WITH KNOB, 1/4" & 3/8" VALVE |
| 7 | 1 | HE3-1 | END CAP, LEVER, 380 AL, 1/4" & 3/8" VALVE |
| 6 | 1 | S3 | SPOOL - STANDARD, 2 POS, CLSD CTR, 1/4" & 3/8" VALVE |
| 5 | 1 | SEC3 | END CAP, 304 STAINLESS STEEL, 1/4" & 3/8" VALVE |
| 4 | 4 | V-37 | SCREW, 10-24 X 1/2, SOCKET HEAD CAP |
| 3 | 2 | ECG3 | GASKET - END CAP, 1/4" & 3/8" VALVE |
| 2 | 6 | V-39 | O-RING, VITON, STD BODY, 1/4" & 3/8" VALVES |
| 1 | 1 | B2-2E | BODY - SOLID, PLAIN, NO PILOTS, ANODIZED, 1/4" SIDE PORT VALVE |

| | | | | |
|---|-----------------|--|--------------------------|--|
| LIMITS ON DIMENSIONS UNLESS OTHERWISE SPECIFIED | | 2-PL DECIMAL ± .01 3-PL DECIMAL ± .005 FRACTIONAL ± 1/64 ANGULAR ± 1/2° | | AAA PRODUCTS INTERNATIONAL 7114 Harry Hines Blvd Dallas, TX 75235 |
| DRAWN: RMckenna | DATE: 9/16/2015 | CHECKED: KWaite | DATE: 9/16/2015 | |
| SCALE: 1 : 1 | SHEET: 1 OF 1 | RELEASED: HWomack | DATE: 9/16/2015 | |
| TITLE: 1/4" SIDE PORT, LEVER, 2 POS, FRICTION POS, LEVER RTRN, 180D LEVER | | | PART NO.: HE2T | REV.: |

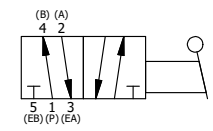

4 | 3 | 2 | 1

THE INFORMATION CONTAINED WITHIN THIS DOCUMENT IS PROPRIETARY TO AAA PRODUCTS AND MAY NOT BE DISCLOSED WITHOUT PRIOR WRITTEN CONSENT

D:\Engineering\product\Valve Assembly\Level\HE2T.dwg