

4 | 3 | 2 | 1

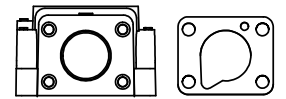

POSITION GASKET ON END OF VALVE SO MOUNTING HOLES ALIGN BOTH ENDS (SIDE 'A' SHOWN)

NOTES:
 1) ALWAYS GIVE VALVE MODEL, AND PART NUMBER WHEN ORDERING PARTS.
 2) APPLY ANTI-SEIZE COMPOUND LIGHTLY TO THE FIRST 1/4" OF THE SCREW THREAD. APPLICATION SHOULD BE AROUND THE THREAD OF THE SCREW.

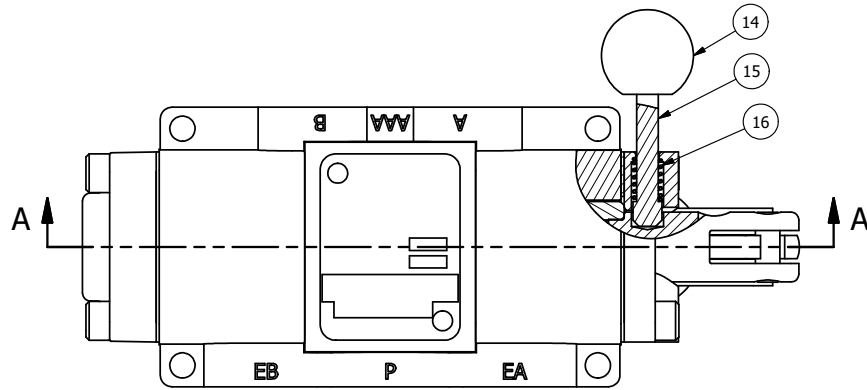
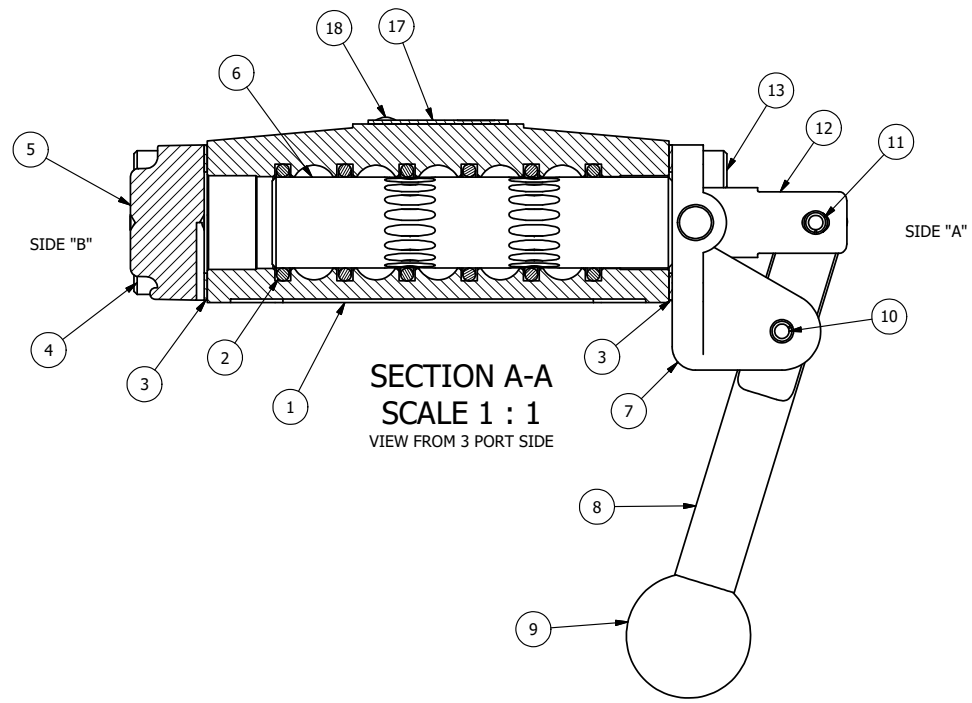

18	2	V-212	SCREW, #2 X 3/16 DRIVE, TYPE U, OVAL HEAD, STAINLESS STEEL
17	1	AN-106	NAMEPLATE, BLANK, STAINLESS STEEL
16	1	BBSS-1	SPRING - BUTTON BLEEDER, STAINLESS STEEL, 1/8" NPTF
15	1	V-315-SS	PIN, PIN LOCK, 303 STAINLESS, 1/4" & 3/8" VALVE
14	1	V-175	KNOB, BLACK, (BRASS 10-32 INSERT), 3/4 DIA BALL, PIN LOCK
13	4	V-162-SS	SCREW, 10-24 X 5/8, SOCKET HEAD CAP, STAINLESS STEEL
12	1	HC3-2PL	CLEVIS - POS. A & C PINLOCKS, STAINLESS, 1/4" & 3/8" VALVE
11	1	V-48-SS	PIN, ROLL 3/16 X 9/16 18-8 STAINLESS
10	1	V-508-SS	PIN, ROLL 3/16 X 5/8", 18-8 SS
9	1	V-521	KNOB, RED (BRASS 3/8-16 INSERT), 1" DIA BALL, 1/4" & 3/8" VALVE
8	1	HL3-SS	HAND LEVER, 303 STAINLESS STEEL, 1/4" & 3/8" VALVE
7	1	HE3-5PLL	END CAP, LEVER, PIN LOCK, LEFT, 303 STAINLESS STEEL, 1/4" & 3/8" VALVE
6	1	SSH3-SS	SPOOL - STANDARD, 2 POS, CLSD CTR, STAINLESS, 1/4" & 3/8" VALVE
5	1	SEC3-3	END CAP, VENTED, STAINLESS STEEL, 1/4" & 3/8" VALVES
4	4	V-38-SS	SCREW, 10-24 X 3/4, SOCKET HEAD CAP, 18-8 SS
3	2	ECG3	GASKET - END CAP, 1/4" & 3/8" VALVE
2	6	V-39	O-RING, VITON, STD BODY, 1/4" & 3/8" VALVES
1	1	B2-2-SS	BODY - STAINLESS STEEL, PLAIN, NO PILOTS, 1/4" SIDE PORT VALVE
FLG	QTY	PART NO	DESCRIPTION

LIMITS ON DIMENSIONS UNLESS OTHERWISE SPECIFIED		2-PL DECIMAL ± .01 3-PL DECIMAL ± .005 FRACTIONAL ± 1/64 ANGULAR ± 1/2°		AAA PRODUCTS INTERNATIONAL 7114 Harry Hines Blvd Dallas, TX 75235
DRAWN: RMckenna	DATE: 5/30/2022	CHECKED: KWaite	DATE: 5/30/2022	
SCALE: 1 : 1	SHEET: 1 OF 1	RELEASED: HWomack	DATE: 5/30/2022	
TITLE: 1/4" SIDE PORT, LEVER, 2 POS, PINLOCK A & C, STAINLESS, RED KNOB, 180D LVR			PART NO.: HE2EJTSS	REV.:

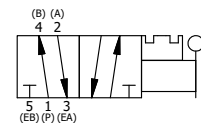

4 | 3 | 2

THE INFORMATION CONTAINED WITHIN THIS DOCUMENT IS PROPRIETARY TO AAA PRODUCTS AND MAY NOT BE DISCLOSED WITHOUT PRIOR WRITTEN CONSENT

D:\Engineering\Products\Valves\Assembly\Level1\HE2EJTSS.dwg