

4 | 3 | 2 | 1

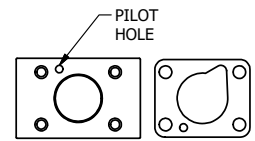
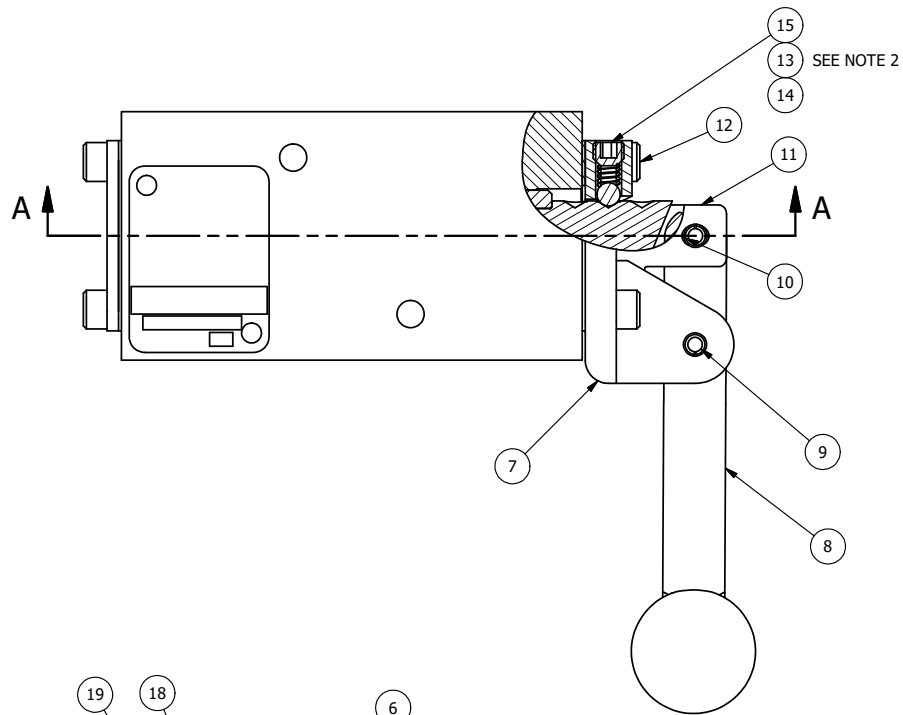

POSITION GASKET TO SEAL PILOT HOLE BOTH SIDES. (SIDE 'A' SHOWN)

NOTES:
 1) ALWAYS GIVE VALVE MODEL, AND PART NUMBER WHEN ORDERING PARTS.
 2) LUBRICATE DETENT BALL, SPRING AND CLEVIS.

| | | | |
|-----|-----|------------|--|
| 20 | 1 | NSPK-2 | KIT - SUBPLATE MOUNTING, NAMUR VALVES |
| 19 | 2 | V-212 | SCREW, #2 X 3/16 DRIVE, TYPE U, OVAL HEAD, STAINLESS STEEL |
| 18 | 1 | AN-114 | NAMEPLATE, BLANK, FOR VALVES WITH SPRINGS OR DETENTS |
| 17 | 1 | V-548 | O-RING, BUNA-N, 70 DURO, 6MM X 1MM, NAMUR PLUG |
| 16 | 1 | V-547 | PLUG, 360 HALF HARD BRASS, NAMUR VALVE |
| 15 | 1 | V-21 | SCREW, 1/4-20 X 3/16, SOCKET SET, CUP POINT |
| 14 | 1 | DS3 | SPRING - DETENT, 1/4" & 3/8" VALVE |
| 13 | 1 | V-14 | BALL, CHROME STEEL 3/16 DIA, GRADE 25, FOR DETENT |
| 12 | 4 | V-162 | SCREW, 10-24 X 5/8, SOCKET HEAD CAP |
| 11 | 1 | BHC3-3 | CLEVIS - TRIPLE DETENT, 1/4" & 3/8" STACKING VALVE |
| 10 | 1 | V-48 | PIN, ROLL 3/16 X 9/16, STEEL, ZINC PLATED |
| 9 | 1 | V-542 | PIN, ROLL 3/16 X 1/2 ZINC PLATED STEEL FOR HE3-4 END CAP |
| 8 | 1 | HL3-521B20 | HAND LEVER WITH RED KNOB, BENT 20 DEG SIDEWAYS, 1/4" & 3/8" VALVES |
| 7 | 1 | HE3-4D | ENDCAP - HAND, DETENT, 303 STAINLESS, 1/4" & 3/8" STACK VALVE |
| 6 | 1 | S3 | SPOOL - STANDARD, 2 POS, CLSD CTR, 1/4" & 3/8" VALVE |
| 5 | 1 | SEC3 | END CAP, 304 STAINLESS STEEL, 1/4" & 3/8" VALVE |
| 4 | 4 | V-37 | SCREW, 10-24 X 1/2, SOCKET HEAD CAP |
| 3 | 2 | ECG3 | GASKET - END CAP, 1/4" & 3/8" VALVE |
| 2 | 6 | V-39 | O-RING, VITON, STD BODY, 1/4" & 3/8" VALVES |
| 1 | 1 | B2-11E-W | NAMUR INTERFACE, WITH 3/2 CONVERSION, 1/4" VALVE |
| FLG | QTY | PART NO | DESCRIPTION |

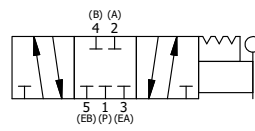
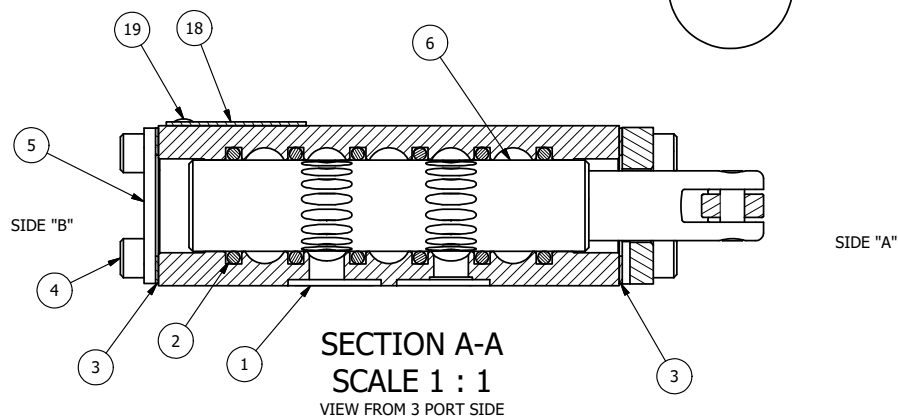

| | | | |
|--|---------------------|--|------------------|
| LIMITS ON DIMENSIONS UNLESS OTHERWISE SPECIFIED | 2-PL DECIMAL ± .01 | AAA PRODUCTS INTERNATIONAL 7114 Harry Hines Blvd Dallas, TX 75235 | |
| | 3-PL DECIMAL ± .005 | | |
| | FRACTIONAL ± 1/64 | | |
| | ANGULAR ± 1/2° | | |
| DRAWN: RMckenna | DATE: 12/28/2022 | CHECKED: KWaite | DATE: 12/28/2022 |
| SCALE: 1 : 1 | SHEET: 1 OF 1 | RELEASED: HWomack | DATE: 12/28/2022 |
| TITLE: 1/4" NAMUR, LEVER, 3 POS, DETENT, LEVER RTRN, BNT LVR RIGHT, RED KNOB, 270D LVR | | PART NO.: NHD2BRJRT | REV.: |

THE INFORMATION CONTAINED WITHIN THIS DOCUMENT IS PROPRIETARY TO AAA PRODUCTS AND MAY NOT BE DISCLOSED WITHOUT PRIOR WRITTEN CONSENT

4 | 3 | 2 | 1

P:\Engineering\Products\Valves\Assembly\lever\HD\AAA\NHD2BRJRT.dwg