

POSITION GASKET ON END OF VALVE SO
GASKET COVERS PILOT HOLE
BOTH SIDES (SIDE 'A' SHOWN)

- NOTES:
1) ALWAYS GIVE VALVE MODEL AND PART NUMBER WHEN ORDERING PARTS.
2) LUBRICATE SPRINGS, AND DETENT BALL.

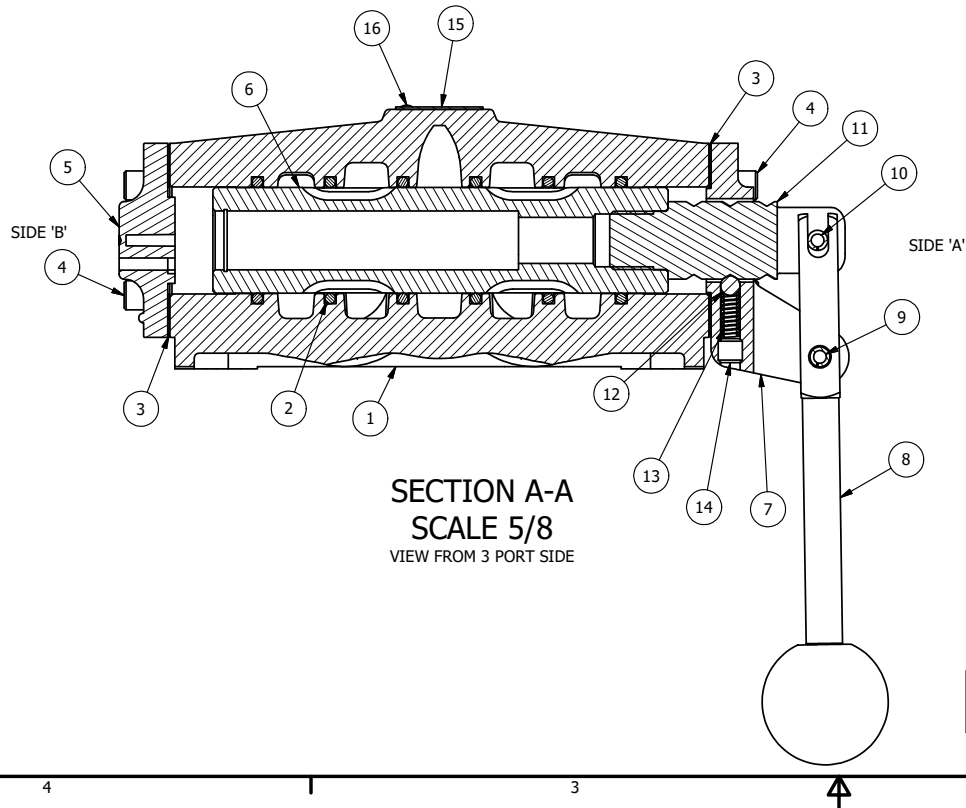

16	2	V-212	SCREW, #2 X 3/16 DRIVE, TYPE U, OVAL HEAD, STAINLESS STEEL
15	1	AN-114	NAME PLATE, BLANK, FOR VALVES WITH SPRINGS OR DETENTS.
14	1	V-8	SCREW, 5/16-18 X 5/16, SOCKET SET, CUP POINT
13	1	DS48	SPRING - DETENT, 1/2", 3/4" & 1" VALVE
12	1	V-4	BALL, CHROME STEEL 1/4 DIA. FOR DETENT
11	1	SC8-3	CLEVIS - 3 POS. DETENT, 3/4" & 1" VALVE
10	1	V-51-SS	PIN, ROLL 1/4 X 1 FOR 3/4 & 1" HAND FOOT & CAM VALVES, STAINLESS STEEL
9	1	V-70	PIN, ROLL 1/4 X 1 1/8 FOR 3/4 & 1" HAND AND FOOT VALVES
8	1	HL8-9	HAND LEVER ASSEMBLY, 3/4" & 1" VALVE
7	1	FE8-3	END CAP, HAND & FOOT, DETENT, STEEL, NICKEL PLT, 3/4" & 1" VALVES
6	1	SSH8G	SPOOL - 'G', 3 POS, FLOAT CTR, 3/4" & 1" VALVE
5	1	PEC48-3	END CAP, VENTED, 380 AL, 1/2", 3/4" & 1" VALVES
4	8	V-46	SCREW, 1/4-20 X 3/4, SOCKET HEAD CAP
3	2	ECG48	GASKET - END CAP, 1/2", 3/4" & 1" VALVE
2	6	V-30	O-RING, BUNA-N, 70 DURO, AS-220, (REF 1-3/8 X 1-5/8 X 1/8), 3/4" & 1" VALVES
1	1	B8-1	BODY, 1" SIDE PORT, UPPER PILOTS, ANODIZED
FLG	QTY	PART NO	DESCRIPTION

LIMITS ON DIMENSIONS
UNLESS
OTHERWISE SPECIFIED

2-PL DECIMAL ± .01
3-PL DECIMAL ± .005
FRACTIONAL ± 1/64
ANGULAR ± 1/2°



DRAWN: RMckenna DATE: 9/16/2015

CHECKED: KWaite DATE: 9/16/2015

SCALE: 3/4 SHEET: 1 OF 1

RELEASED: HWomack DATE: 9/16/2015

TITLE:
1" SIDE PORT, LEVER, 3 POS,
DETENT, LEVER SHFT, FLOAT CTR SPL,
180D LEVER

PART NO.:
HD8GT

REV.:

THE INFORMATION CONTAINED WITHIN THIS DOCUMENT IS PROPRIETARY TO AAA PRODUCTS AND MAY NOT BE DISCLOSED WITHOUT PRIOR WRITTEN CONSENT

D:\Engineering\product\Valve Assembly\Level\HD8GT\HD8GT.dwg